

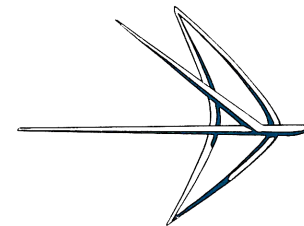

Your
CESSNA
150

ON YOUR TRAVELS, STOP AT CESSNA
SERVICE STATIONS FOR FAST,
EFFICIENT, ECONOMICAL SERVICE.



1959-1960

OWNER'S MANUAL

CESSNA AIRCRAFT COMPANY WICHITA, KANSAS



Congratulations

Welcome to the ranks of Cessna owners! Your Cessna has been designed and constructed to give you the most in performance, economy, and comfort. You will find flying it, either for business or pleasure, a pleasant and profitable experience.

This Owner's Manual has been prepared as a guide to help you get the most pleasure and utility from your airplane. It contains information about your Cessna's equipment, operating procedures, and performance; and suggestions for its servicing and care. We urge you to read it from cover to cover, and to refer to it frequently.

Our interest in your flying pleasure has not ceased with your purchase of a Cessna. World-wide, the Cessna Dealer Organization backed by the Cessna Service Department stands ready to serve you. The following services are offered only by your Cessna Dealer:

FACTORY TRAINED MECHANICS to provide you with courteous expert service.

FACTORY APPROVED SERVICE EQUIPMENT to provide you with the most efficient and accurate workmanship possible.

A STOCK OF GENUINE CESSNA SERVICE PARTS on hand when you need them.

THE LATEST AUTHORITATIVE INFORMATION FOR SERVICING CESSNA AIRPLANES, since Cessna Dealers have all of the Service Manuals and Parts Catalogs, kept current by Service Letters and Service News Letters published by Cessna Aircraft Company.

We urge all Cessna owners to use the Cessna Dealer Organization to the fullest.

A current Cessna Dealer Directory accompanies your new airplane. The Directory is revised frequently, and a current copy can be obtained from your Cessna Dealer. Make your Directory one of your cross-country flight planning aids; a warm welcome awaits you at every Cessna Dealer.

WARRANTY

■ The Cessna Aircraft Company warrants each new airplane, manufactured by it, to be free from defects in material and workmanship under normal use and service, provided, however, that this warranty is limited to making good at the Cessna Aircraft Company's factory any part or parts thereof which shall, within ninety (90) days after delivery of such airplane to the original purchaser, be returned to the Company with transportation charges prepaid, and which upon Company examination shall disclose to the Company satisfaction to have been thus defective; this warranty being expressly in lieu of all other warranties expressed or implied and all other obligations or liabilities on the part of the Company, and the Company neither assumes nor authorizes any other person to assume for it any other liability in connection with the sale of its airplanes.

■ This warranty shall not apply to any airplane which shall have been repaired or altered outside the Company's factory in any way so as, in its judgment, to affect its stability or reliability, nor which has been subject to misuse, negligence or accident.

Index

I (Cont)	R
Instruments, 1-6	Rotating Beacon, 1-15
Inspections, 5-5	
Interior Care,	S
Instrument Lights, 1-14	
L	Seats, 1-16
Landing, 2-4, 3-5	Speed Fairings, 1-12
Landing Distances, 6-2	Removal,
Landing Gear System, 1-12	Stalls, 3-5, 4-1
Landing Lights, 1-14	Stall Warning Indicator, 1-6
Let-Down, 3-1	Starter Handle, 1-3
Lighting Equipment, 1-14	Starting, 2-1
Loading Graph, 4-4	Storage, 5-2
Lubrication and Servicing, 5-7	
5-8, 5-9	T
M	Tachometer, 4-2
Main Landing Gear, 1-11	Take-Off, 2-2, 2-3, 3-1, 3-5
Master Switch, 1-9	Take-Off Distances, 6-2
Miscellaneous Equipment, 1-16	Taxiing, 3-3
Mixture Control, 1-1	Turn and Bank Indicator, 1-6
N	U
Navigation Lights, 1-14	Utility Shelf, 1-17
Nose Gear, 1-11	Use of Carburetor Heat, 3-3
O	W
Oil Pressure Gage Markings, 4-2	Warm-Up, 2-1
Oil System, 1-7	Weight and Balance, 4-3
Oil System Instruments, 1-7	Wheels and Tires, 1-12, 5-3, 5-4
Oil Temperature Gage	Wing Flap Handle, 1-3
Markings, 4-2	Wing Flap Settings, 1-5
Operations Authorized, 4-1	
P	
Pitot System Instruments, 1-6	
Principal Dimensions, iv	

Table of Contents

	Page
SECTION I - DESCRIPTION	1-1
SECTION II - OPERATING CHECK LIST	2-1
SECTION III - OPERATING DETAILS	3-1
SECTION IV - OPERATING LIMITATIONS	4-1
SECTION V - CARE OF THE AIRPLANE	5-1
CROSS COUNTRY SERVICE	5-10
SECTION VI - PERFORMANCE DATA	6-1
ALPHABETICAL INDEX	Index-1

This manual describes the operation and performance of the 1959 and 1960 Standard, Trainer, and Inter-City Commuter configurations of the Cessna Model 150 airplane. Equipment described as "Optional" is either furnished as additional equipment in the Trainer and Inter-City Commuter or is available as optional equipment for any of the three configurations.

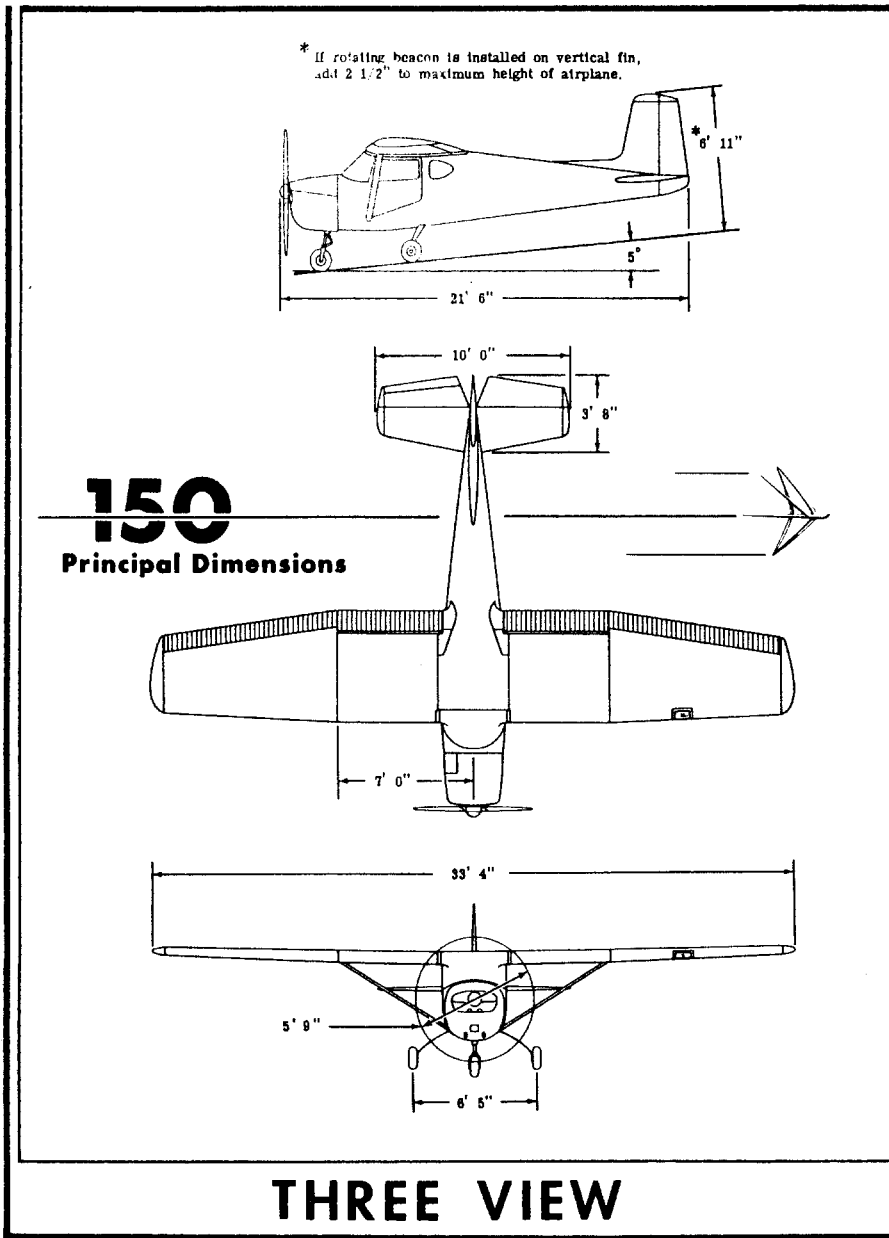

Figure 1-1.

Alphabetical Index

- | | |
|---|--|
| <p>A</p> <p>After Landing, 2-4
Airplane File, 5-6
Airspeed
 Correction Table, 6-1
 Indicator Markings, 4-2
 Limits, 4-2</p> <p>B</p> <p>Battery, 1-9
Baggage Compartment, 1-17
Before Entering Airplane, 2-1
Before Starting the Engine, 2-1
Before Take-Off, 2-2
Before Landing, 2-4
Brake System, 1-12</p> <p>C</p> <p>Cabin Doors, 1-16
Cabin Heating and Ventilating System, 1-12
Cabin Windows, 1-16
Carburetor Air Heat Knob, 1-1
Carburetor Air Filtering System, 1-7, 5-9
Child's Seat, 1-16
Cold Weather Operation, 3-6
Climb, 2-3, 3-5, 6-2
Cruising, 2-3, 3-5, 6-3
Controls Lock, 1-5, 5-1</p> <p>D</p> <p>Directional Gyro, 1-6
Dome Light, 1-14</p> | <p>E</p> <p>Electrical System, 1-9
Elevator Trim Tab Control Wheel, 1-4
Engine, 1-1
 Instrument Markings, 4-2
 Operation Limitations, 4-2
 Operating Procedures, 3-1
 Primer, 1-1, 3-7
Entry Speeds, 4-1
Exterior Care, 5-2</p> <p>F</p> <p>Fire Extinguisher, 1-17
Flaps, 1-4
Flight Controls, 1-3
Flight Maneuvering Load Factors, 4-1
Fuel Quantity Indicators, 4-2
Fuel Shutoff Valve, 1-7
Fuel System, 1-7
 Instruments, 1-9
Fuses, 1-11</p> <p>G</p> <p>Generator Warning Light, 1-11
Ground Handling, 5-1</p> <p>H</p> <p>Heating and Ventilation System, 1-12</p> <p>I</p> <p>Ignition Switch, 1-1</p> |
|---|--|

Notes

SECTION 1

Description

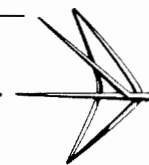

One of the first steps in obtaining the utmost performance, service, and flying enjoyment from your Cessna is to familiarize yourself with your airplane's equipment, systems, and controls. This section will discuss location, operation, and function of the various items of equipment, emphasizing description of equipment that is not readily understood at first inspection.

THE ENGINE.

The powerplant used in your Cessna is a four-cylinder, 100-horsepower, Continental Model O-200-A engine. The engine uses a wet sump oil system, dual magneto ignition system, and up-draft type carburetion system.

MIXTURE CONTROL KNOB.

The mixture control (figure 1-3) incorporates a locking lever to prevent unintentional use of the mixture control knob. To lean the mixture, it is necessary to depress the locking lever while pulling the mixture control knob out. This operation can be accomplished with one hand by using the thumb to press the locking lever in and the index and middle fingers to pull the knob out. The locking lever is effective only in the leaning operation. Forward movement of the mixture control knob is not affected by the locking lever.

CARBURETOR AIR HEAT KNOB.

The carburetor air heat knob (figure 1-3) operates the carburetor air intake butterfly valve, which proportions hot and cold air entering the carburetor. Pulling the knob out provides heated air for the carburetor while pushing the knob all the way in provides only cold air.

IGNITION SWITCH.

The key-operated ignition switch (figure 1-2) controls the dual magneto ignition system. The switch has four positions labeled clockwise as follows: "OFF," "R," "L," and "BOTH." The engine should be operated on both magnetos ("BOTH" position). The "R" and "L" positions are for checking purposes only.

ENGINE PRIMER KNOB.

The engine primer in your airplane is a manual plunger type, and is op-

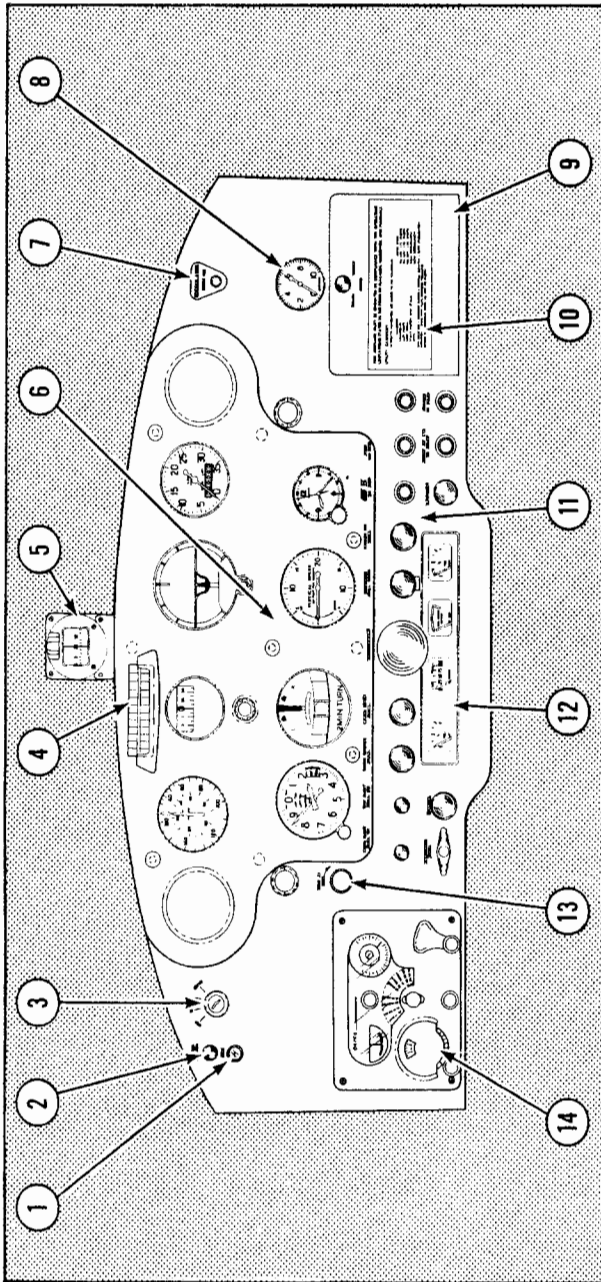

- 1. Generator Warning Light
- 2. Master Switch
- 3. Ignition Switch
- 4. Compass Correction Card
- 5. Magnetic Compass
- 6. Flight Instrument Grouping
- 7. Rotating Beacon Switch (Optional Equipment)
- 8. Suction Gage (Optional Equipment)
- 9. Map Compartment
- 10. Operation Limitations Placard
- 11. Switch and Control Panel (See figure 1-3)
- 12. Fuel and Oil Instruments
- 13. Instrument Lights Rheostat Knob
- 14. Radio (Optional Equipment)

Figure 1-2. Instrument Panel

CRUISE PERFORMANCE					WITH LEAN MIXTURE			
ALTITUDE	RPM	HP	TAS MPH	GAL/HR.	* END. HOURS		* RANGE, MILES	
					22.5 GAL.	35 GAL.	22.5 GAL.	35 GAL.
2500	2750	85	124	6.4	3.5	5.5	435	680
	2700	81	121	6.1	3.7	5.7	450	695
	2600	72	115	5.4	4.2	6.5	480	745
	2500	64	110	4.8	4.7	7.3	515	800
	2400	57	104	4.3	5.2	8.1	540	845
	2300	52	99	4.0	5.6	8.8	555	870
2200	47	94	3.7	6.1	9.5	570	890	
5000	2750	80	123	6.0	3.7	5.8	465	720
	2700	73	120	5.5	4.1	6.4	490	765
	2600	67	114	5.0	4.5	7.0	510	800
	2500	60	109	4.6	4.9	7.6	540	830
	2400	54	103	4.1	5.5	8.5	565	875
	2300	49	98	3.8	5.9	9.2	580	905
2200	45	92	3.5	6.4	10.0	590	920	
7500	2750	74	122	5.5	4.1	6.4	495	780
	2700	69	119	5.2	4.3	6.7	515	800
	2600	63	113	4.7	4.8	7.5	535	840
	2500	57	108	4.3	5.2	8.2	565	880
	2400	51	102	3.9	5.7	9.0	585	915
	2300	47	98	3.7	6.1	9.5	600	925
2200	44	93	3.5	6.5	10.0	610	930	
10000	2740 (Full Throttle)	68	120	5.1	4.4	6.9	530	825
	2700	65	118	4.9	4.6	7.2	540	845
	2600	59	112	4.5	5.0	7.8	560	870
	2500	54	107	4.1	5.5	8.6	590	915
	2400	49	102	3.8	6.0	9.2	605	940
	2300	46	98	3.6	6.3	9.7	615	955
2200	43	95	3.4	6.6	10.3	630	980	
12500	2700 (Full Throttle)	61	116	4.6	4.9	7.6	570	860
	2600	56	111	4.2	5.3	8.3	585	920
	2500	52	106	4.0	5.7	8.8	600	935
	2400	48	103	3.8	6.0	9.2	620	950
	2300	45	97	3.5	6.4	10.0	625	970
	2200	43	93	3.4	6.6	10.3	610	960

* No allowances for take-off or reserve.

NOTE: Shaded areas are cruising RPM settings that are not recommended for the given altitude.

Figure 6-3. Cruise Performance Chart

TAKE-OFF DISTANCE							FLAPS RETRACTED - ZERO WIND		HARD SURFACE RUNWAY	
GROSS WEIGHT, LBS.	AT SEA LEVEL & 59° F.		AT 2500 FT. & 50° F.		AT 5000 FT. & 41° F.		AT 7500 FT. & 32° F.		TOTAL TO CLEAR 50' OBSTACLE	
	IAS, MPH AT 50 FT.	GROUND RUN	TOTAL TO CLEAR 50' OBSTACLE	GROUND RUN	TOTAL TO CLEAR 50' OBSTACLE	GROUND RUN	TOTAL TO CLEAR 50' OBSTACLE	GROUND RUN	TOTAL TO CLEAR 50' OBSTACLE	
1500	61	680	1205	830	1440	1013	1760	1274	2212	

NOTE: Decrease the distances shown by 10% for each 4 knots of headwind. Increase the distances 10% for each 35° F. increase in temperature above standard for the particular altitude.

CLIMB DATA							AT 10000 FT. & 23° F.		AT 15000 FT. & 5° F.		
GROSS WEIGHT, LBS.	AT SEA LEVEL & 59° F.		AT 5000 FT. & 41° F.		AT 10000 FT. & 23° F.		AT 15000 FT. & 5° F.		FUEL USED FROM S.L., GAL.		
	BEST CLIMB IAS, MPH	RATE OF CLIMB FT./MIN.	FUEL USED, GAL.	BEST CLIMB IAS, MPH	RATE OF CLIMB FT./MIN.	FUEL USED FROM S.L., GAL.	BEST CLIMB IAS, MPH	RATE OF CLIMB FT./MIN.	BEST CLIMB IAS, MPH	RATE OF CLIMB FT./MIN.	
1500	71	740	.6	68	530	1.5	66	320	63	115	4.5

NOTE: Flaps retracted, full throttle, mixture leaned to smooth operation above 5000 ft. Fuel used includes warm-up and take-off allowances.

LANDING DISTANCE							FLAPS LOWERED TO 40° - POWER OFF		HARD SURFACE RUNWAY - ZERO WIND	
GROSS WEIGHT, LBS.	AT SEA LEVEL & 59° F.		AT 2500 FT. & 50° F.		AT 5000 FT. & 41° F.		AT 7500 FT. & 32° F.		TOTAL TO GROUND ROLL	
	APPROACH SPEED, IAS, MPH	TOTAL TO CLEAR 50' OBSTACLE	GROUND ROLL	TOTAL TO CLEAR 50' OBSTACLE	GROUND ROLL	TOTAL TO CLEAR 50' OBSTACLE	GROUND ROLL	TOTAL TO CLEAR 50' OBSTACLE	GROUND ROLL	TOTAL TO CLEAR 50' OBSTACLE
1500	59	1055	360	1100	390	420	1230	465		

NOTE: Decrease the distances shown by 10% for each 4 knots of headwind. Increase the distance by 10% for each 60° F. temperature increase above standard.

Figure 6-2. Take-Off, Climb and Landing Chart

erated by the engine primer knob (figure 1-3). It is used to aid in starting the engine by supplying an initial charge of raw fuel to the cylinders. For an initial start in normal air temperatures, use two strokes of the primer. Usually, a hot engine will need no priming. To operate the primer, proceed as follows:

- (1) First, unlock the plunger by rotating the knob in either direction until the knob pops part way out.
- (2) Slowly pull the plunger all the way out and then push it all the way in. This action is termed "one stroke of the primer."
- (3) Normal winter weather will require two to four strokes of the primer, and very cold (-20° F) weather may require ten strokes.
- (4) Normally, the engine is started immediately after the priming operation. In very cold weather, it is recommended that the engine be turned over while priming. It may be necessary to continue priming until the engine runs smoothly.

STARTER HANDLE.

Pulling out on the "T" shaped starter handle (figure 1-3) engages the engine starter. It is spring-loaded to return to the disengaged position.

NOTE

Do not pull out the starter handle with the propeller turning. Engaging the starter with the engine rotating may damage the starter drive.

FLIGHT CONTROLS.

Conventional wheel and rudder pedal controls on the left side of the airplane operate the primary flight control surfaces (ailerons, elevators, and rudder). In addition, a control wheel and rudder pedals may be provided as optional equipment on the right side.

ELEVATOR TRIM TAB CONTROL WHEEL.

The elevator trim tab, located on the right elevator, is mechanically operated by the elevator trim tab control wheel on the floor just forward of the seats. A tab position indicator is incorporated in the tab control wheel mechanism to show the nose-up or nose-down setting of the tab. Forward rotation of the wheel trims nose-down, and rearward rotation trims nose-up. Take-off should be made with the tab position indicator set at the "TAKE-OFF" position labeled on the indicator cover.

WING FLAP HANDLE.

The wing flaps are controlled by a wing flap handle mounted between the seats. The handle is operated by depressing the thumb button and pulling the handle up and aft to the desired flap setting. By releasing the thumb button, the handle can be locked to provide 0, 10, 20, 30, and 40 degree flap positions.

The flaps may be lowered or raised during normal flying whenever the airspeed is less than 85 MPH. The use of flaps is not recommended for crosswind take-offs. For unusually

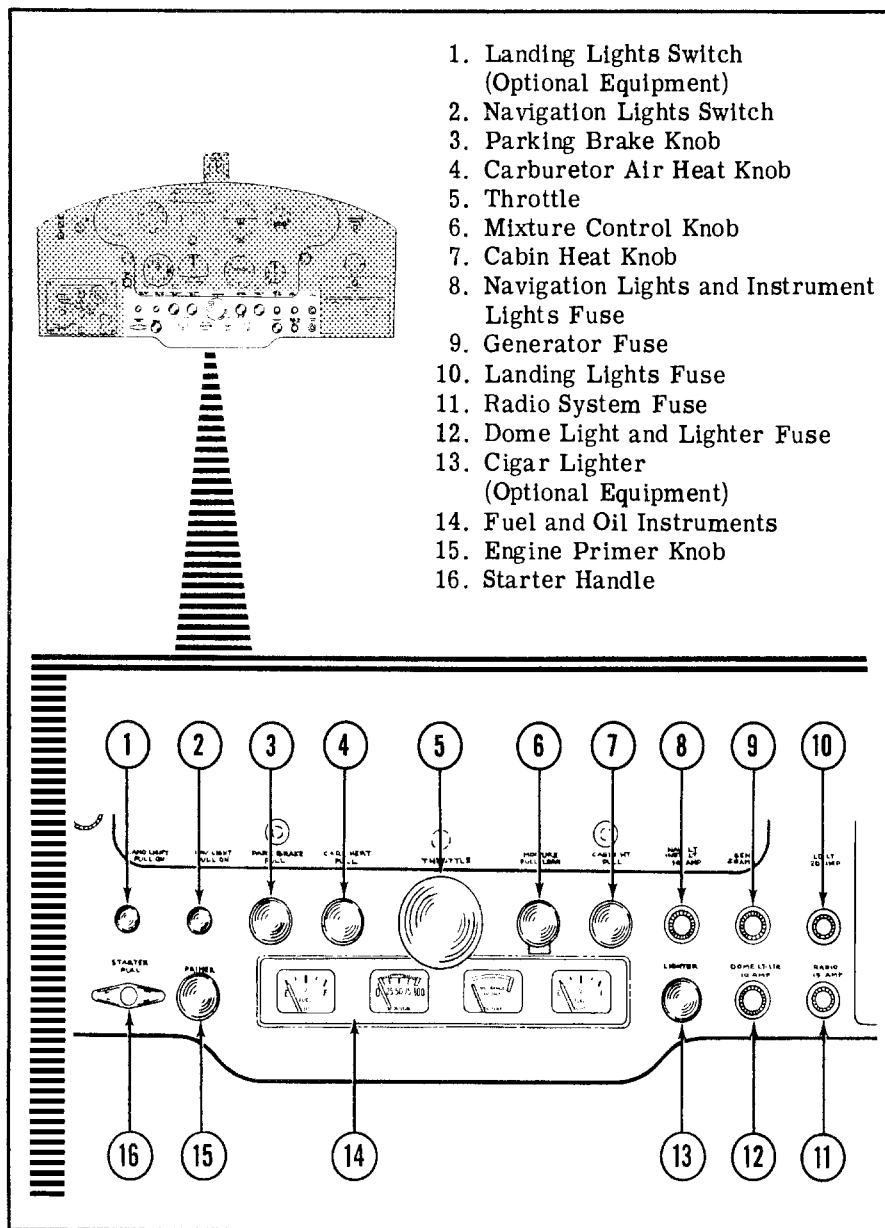

Figure 1-3. Switch and Control Panel

SECTION VI

Performance Data



The operational data shown on the following pages are compiled from actual tests with airplane and engine in good condition, and using average piloting technique and best power mixture. You will find this data a valuable aid when planning your flights. However, inasmuch as the number of variables included precludes great accuracy, an ample fuel reserve should be provided. The range performance shown makes no allowance for wind, navigational error, pilot technique, warm-up, take-off, climb, etc. which may be different on each flight you make. All of these factors must be considered when estimating reserve fuel.

To realize the maximum usefulness from your 150 you should take advantage of its high cruising speeds. However, if range is of primary importance, it may pay you to fly at a low cruising RPM thereby increasing your range and allowing you to make the trip non-stop with ample fuel reserve. The range table on page 6-3 should be used to solve flight planning problems of this nature.

In the table, (figure 6-3), range and endurance are given for lean mixture from 2500 feet to 12,500 feet. All figures are based on zero wind, 22.5 gallons of fuel for cruise, Sensenich M69CK-52 propeller, 1500 pounds gross weight, and standard atmospheric conditions. Mixture is leaned to maximum RPM. Allowances for fuel reserve, headwinds, take-offs and climb, and variations in mixture leaning technique should be made as no allowances are shown on the chart. Other indeterminate variables such as carburetor metering characteristics, engine and propeller conditions, and turbulence of the atmosphere may account for variations of 10% or more in maximum range.

AIRSPEED CORRECTION TABLE (Flaps Up or Down)											
IAS	40	50	60	70	80	90	100	110	120	130	140
TIAS	52	58	65	73	82	91	100	108	117	126	135

Figure 6-1. Airspeed Correction Table

DEALER FOLLOW-UP SYSTEM

Your Cessna Dealer has an owner follow-up system to notify you when he receives information that applies to your Cessna. In addition, if you wish, you may choose to receive similar notification directly from the Cessna Service Department. A subscription card is supplied to you in your airplane file for your use, should you choose to request this service. Your Cessna Dealer will be glad to supply you with details concerning these follow-up programs, and stands ready through his Service Department to supply you with fast, efficient, low cost service.

short field take-offs, apply 10° flaps (first notch) prior to take-off. For further discussion of the use of wing flaps for take-off, refer to Section III.

WING FLAP SETTINGS

- For Normal Take-off . . . Up (0°)
- For Short Take-off . 1st notch (10°)
- For Landing --
- Select as desired Up (0°)
- 1st notch (10°)
- 2nd notch (20°)
- 3rd notch (30°)
- 4th notch (40°)

CONTROLS LOCK (OPTIONAL EQUIPMENT).

A controls lock is available to lock the ailerons and elevators in neutral position as a protection against dam-

age caused by buffeting in gusty or strong winds. The lock is designed with a large red metal flag which covers the starter handle. This feature prevents starting the engine with the controls lock installed.

To install the controls lock, pull the pilot's control wheel back until the hole in the control wheel shaft is aligned with the locking bracket which circumscribes the control wheel shaft opening on the instrument panel. Position the controls lock under the control wheel shaft so that the lettering on the red flag is legible, then insert the shaft of the controls lock up through the locking bracket and control wheel shaft. Check that the controls lock is fully inserted and that the flag is covering the starter handle. When not

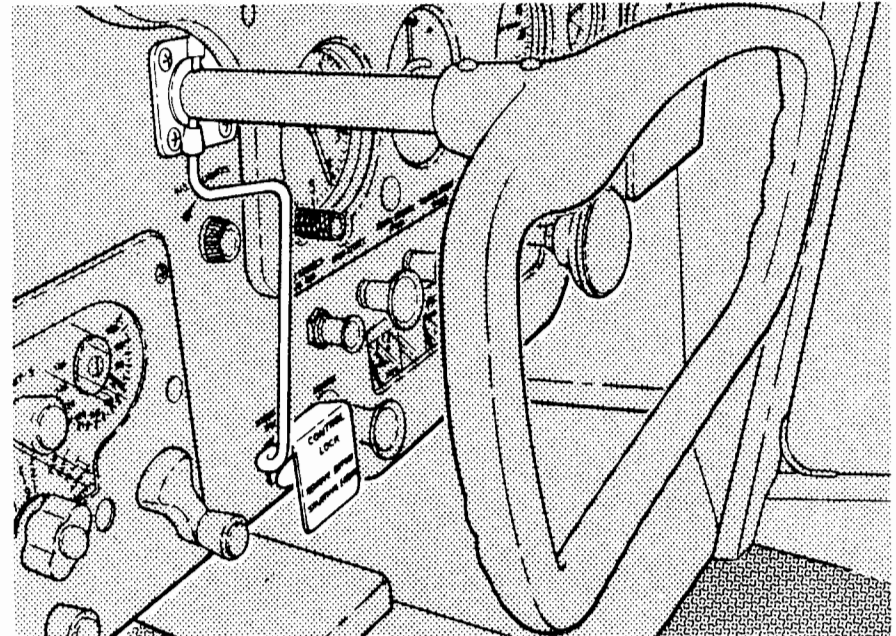

CONTROLS LOCK

in use, the lock is stored in the map compartment.

INSTRUMENTS.

All instruments (figure 1-2) are mounted on the instrument panel except an outside air temperature gage and a magnetic compass. The outside air temperature gage (optional equipment) is located in the right cabin ventilator. For correct readings, the ventilator must be slightly open. The magnetic compass is mounted on the deck just above the instrument panel.

PITOT-STATIC SYSTEM INSTRUMENTS.

Instruments connected to the pitot-static system include the airspeed indicator, altimeter and rate-of-climb indicator (optional equipment). This system functions on differential pressure between impact air pressure at the pitot tube mounted under the leading edge of the left wing and barometric pressure obtained from a static port mounted on the left forward side of the fuselage. To keep the pitot tube opening clean, a cover may be placed over the pitot tube whenever the airplane is idle on the ground. The static port should be kept free of polish, wax, or dirt since these instruments depend on a reliable source of atmospheric pressure for proper operation.

VACUUM-OPERATED INSTRUMENTS (OPTIONAL EQUIPMENT).

Instruments operated by the vacuum system include the directional gyro

and gyro horizon. A suction gage is also included with the vacuum system to indicate the amount of suction available at the instruments.

TURN AND BANK INDICATOR (OPTIONAL EQUIPMENT).

The turn and bank indicator is electrically operated. Turned on by the master switch, the indicator continues to function until the master switch is turned off.

STALL WARNING INDICATOR.

The stall warning indicator is an electric horn, controlled by a sensing unit in the leading edge of the left wing. This system is in operation whenever the master switch is turned on. The sensing unit responds to changes in the airflow over the leading edge as a stall is approached. Since these changes in airflow occur with every stall, the unit functions regardless of attitude, speed, weight, altitude and other factors which effect stalling speed. Thus, it warns you of an inadvertent stall under all conditions. In straight-ahead and turning flight, the warning will come approximately 5 to 10 MPH ahead of the stall.

The only time you may hear the indicator under safe flight conditions will be merely a short beep as you land. Usually no warning will be evident on a properly executed landing. However, if the airplane is leveled off high, the indicator will signal. The indicator automatically cuts out on the ground, although high surface winds may give signals when

LUBRICATION AND SERVICING

1. Fuel Tanks:
Service after each flight with 80/87 octane aviation grade fuel. The capacity of each tank is 13 gallons.
2. Fuel Tank Sump and Fuel Line Drain Plugs:
Remove plugs, drain off water and sediment, and reinstall plugs. Safety wire plugs to adjacent structure.
3. Battery:
Check level of electrolyte at least every 30 days, and oftener in hot weather. Maintain level of electrolyte even with the spill ring at the bottom of the filler hole by adding distilled water. Neutralize any spilled electrolyte at once with baking soda solution, followed by a thorough rinse. Keep battery clean (use baking soda solution, then rinse thoroughly and dry) and battery connections tight.
4. Gyro Instrument Inlet Filters:
Replace on gyro instruments if erratic or sluggish responses are noted with normal suction gage readings.
5. Tires:
Maintain pressure at 30 psi. Inflate tires in accordance with the instructions provided in the bag which contains the filler needle. Periodically inspect tires for general condition. Oil and grease on tires should be removed with soap and water.
6. Wheel Bearings:
Pack with MIL-L-3545 wheel bearing grease at least every 500 hours; oftener if more than the usual amount of water, mud, ice or snow is encountered.
7. Brake Master Cylinders:
Fill with MIL-H-5606 petroleum base hydraulic fluid. Filling with a pressure pot connected to the brake bleeder ports is preferable, although fluid may be poured through the plugs on the top of the master cylinders.
8. Shimmy Dampener:
Fill with MIL-H-5606 petroleum base hydraulic fluid through filler plug on top of cylinder.
9. Nose Gear Shock Strut:
Keep strut inflated and filled. See page 5-7 for detailed instructions.
10. Nose Gear Torque Links:
Lubricate through grease fittings with MIL-L-7711 general purpose grease.
11. Fuel Strainer:
Drain approximately two ounces of fuel to remove water and sediment. Make sure drain valve is closed after draining.
12. Engine Oil Sump:
Drain by removing plug in bottom of sump. Remove lower cowling and provide protection for nosewheel tire when draining.
13. Carburetor Air Filter:
Service in accordance with instructions stamped on the filter frame. Service at least every 25 hours or oftener when operating in dusty conditions. Under extremely dusty conditions, daily maintenance of the filter is recommended.
14. Oil Separator:
Remove separator and flush with Stoddard solvent (Federal Specification P-S-661); then dry with compressed air and reinstall.
15. Engine Oil Screen:
Remove and wash screen (located on right rear side of engine accessory section) with Stoddard solvent (Federal Specification P-S-661) whenever engine oil is changed.
16. Oil Dipstick and Filler Cap:
Remove and check oil level. Oil capacity is 6 quarts. Do not operate with less than 4 quarts and completely fill the sump if an extended flight is planned. Service with aviation grade engine oil; SAE 40 for temperatures above 50°F or SAE 20 for temperatures below 50°F.
17. Oil Filter (Fram PB5):
Replace optional filter whenever oil on dipstick appears dirty. An interval of 100 hours is considered maximum for replacement under average conditions.
18. Suction Relief Valve Inlet Screen:
Check inlet screen for dirt or obstructions if suction gage readings appear high. Remove screen and clean with compressed air or wash with Stoddard solvent (Federal Specification P-S-661).

Figure 5-1. Lubrication and Servicing Diagram (Sheet 2 of 2)

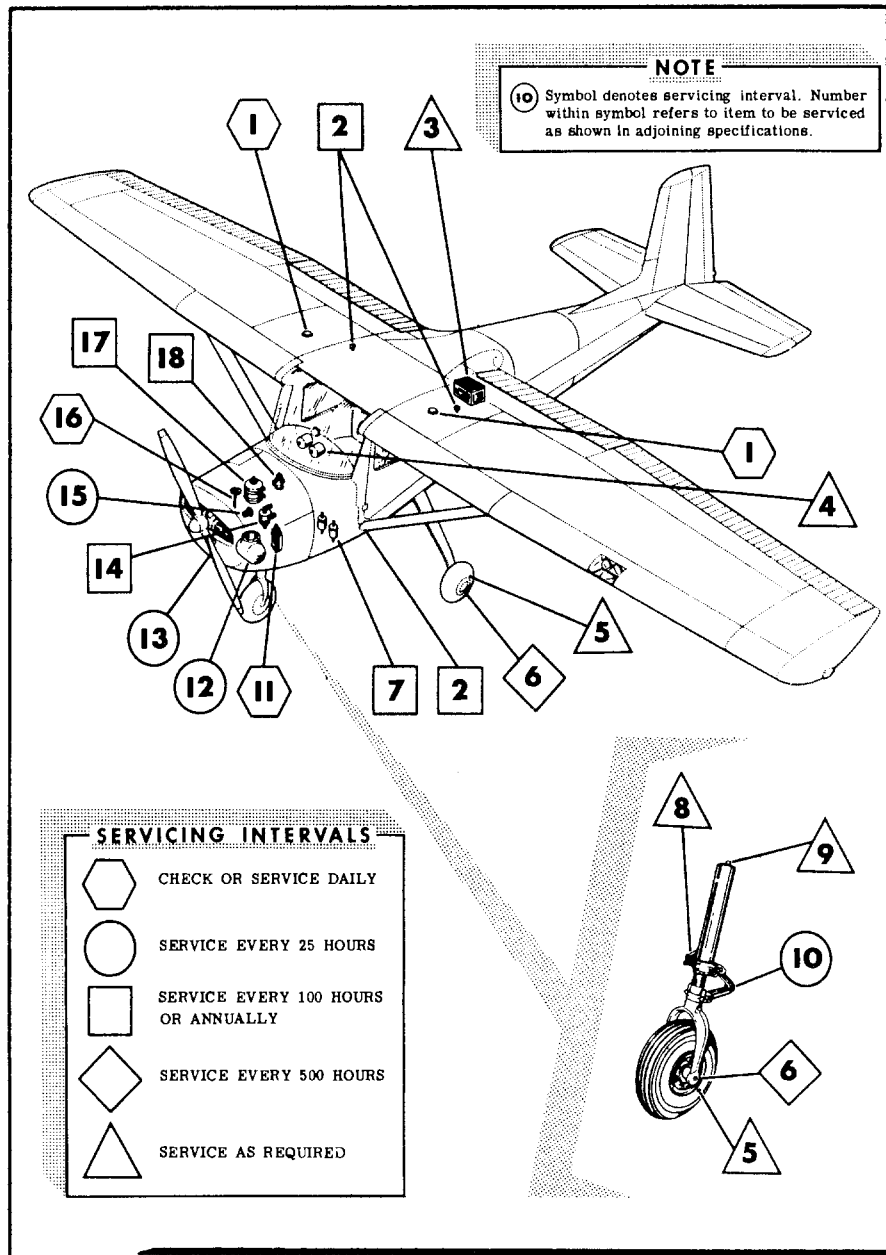

taxing. The unit has no silencing switch which might be inadvertently left off.

OIL SYSTEM.

The oil capacity of the Continental Model O-200-A engine is 6 quarts, 2 quarts of which are considered unusable. Oil should be added if below 4 quarts and should be full if an extended flight is planned. The quantity can be checked by opening the access door on the right side of the engine cowl and reading the oil level on a dipstick which is fastened to the oil filler cap. In replacing the oil filler cap, make sure that it is on firmly and turned clockwise as far as it will go to prevent loss of oil through the filler neck.

Refer to the servicing diagram (figure 5-1) for recommended oil grades, specification and servicing intervals.

OIL SYSTEM INSTRUMENTS.

A capillary type oil temperature gage (figure 1-3) and a direct reading oil pressure gage (figure 1-3) are standard equipment. A green arc on each gage dial indicates the normal operating range. Refer to Section IV for instrument markings.

CARBURETOR AIR FILTERING SYSTEM.

Air is ducted to the carburetor from an air scoop located on the bottom of the engine cowl. Dirt and other foreign matter is filtered from the incoming air by a filter screen

located in the air scoop. Proper cleaning and servicing of this air filter is important to increase life and maintain top efficiency of the engine. Servicing instructions are stamped on the carburetor air filter. Refer to the servicing diagram (figure 5-1) for the servicing interval.

FUEL SYSTEM.

Fuel is supplied to the engine from two 13 gallon wing tanks. From these tanks, fuel flows by means of gravity through a fuel shutoff valve and fuel strainer to the carburetor. The total usable fuel in all flight conditions is 22.5 gallons. With the optional Patroller wing, each tank holds 19 gallons, and the total usable fuel is 35 gallons.

Refer to the servicing diagram (figure 5-1) for the recommended fuel specification and grade, and fuel tank, strainer, and line draining procedure.

FUEL SHUTOFF VALVE.

The fuel shutoff valve is located on the cabin floor just forward of the seats and is safetied in the "ON" position. The "ON" position provides fuel flow from both tanks simultaneously.

NOTE

When emergency operation of the valve is required, a sharp twist of the valve handle toward the "OFF" position will break the safety wire. The "OFF" position seals both tanks off from the rest of the fuel system.

Figure 5-1. Lubrication and Servicing Diagram (Sheet 1 of 2)

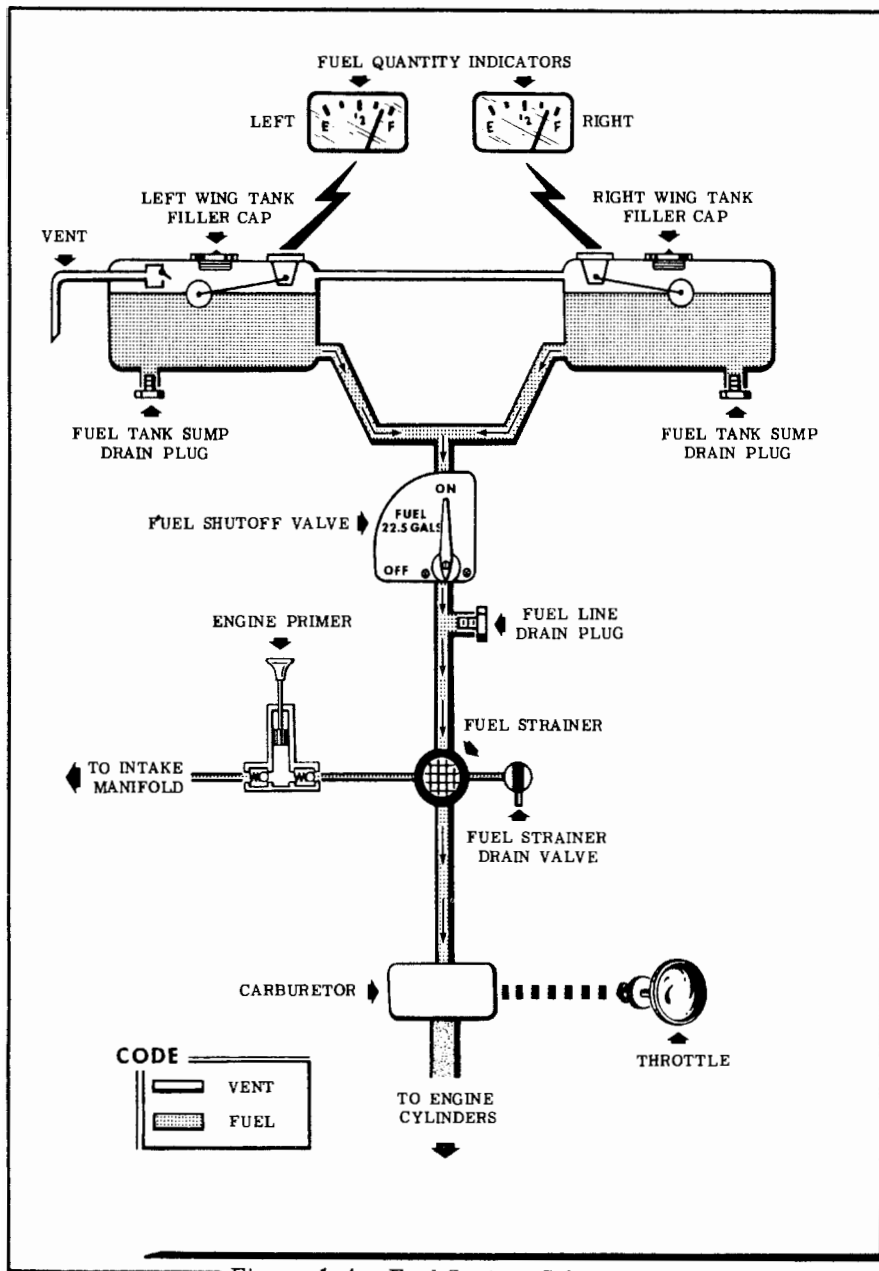

Figure 1-4. Fuel System Schematic

wheel shaft universal, should be lubricated with SAE 20 General Purpose oil every 1,000 hours or oftener as required.

In general, roller chains (aileron, tab wheel, tab actuator) and control cables tend to collect dust, sand and grit when they are greased or oiled. Except under seacoast conditions, more satisfactory operation results when the chains are wiped clean occasionally with a clean, dry cloth.

NOSE GEAR SHOCK STRUT

The nose gear shock strut should be kept clean, filled with fluid and correctly inflated. The exposed portion of the strut piston, particularly, should be wiped off with a cloth moistened in hydraulic fluid, to remove dust and grit which may cut the O-ring seals in the strut barrel.

Inflation of the nose strut should be checked whenever tire pressures are checked. The fluid level should be checked on periodic inspections, and oftener if there is evidence of leakage on the piston or around the filler valve. If the leakage is appreciable or persistent, the strut should be

serviced and repaired as necessary by your Cessna dealer.

To check the strut inflation, jack the nose or lower the tail until the strut is fully extended and the wheel is clear of the ground. Remove the cap on the filler valve and check the pressure with a tire gage, adding or removing air as necessary to obtain 20 psi. Air may be bled out by depressing the stem of the valve core.

Use the following procedure for checking the strut fluid level:

- (1) Working through the right cowl access door, remove the valve cap and depress the valve core stem to release all air pressure.
- (2) Using a 3/4-inch box end or deep socket wrench, unscrew the filler valve and remove it.
- (3) Completely compress the strut, so the stops contact the outer barrel. The fluid level should be even with the bottom of the valve hole. If it is not, add MIL-H-5606 (red) hydraulic fluid.
- (4) Completely extend the strut and replace the filler valve.
- (5) With the strut fully extended and the wheel clear of the ground, inflate the strut to 20 psi. Replace the valve cap.

quotations or charges will be made accordingly. The inspection charge does not include the oil required for the oil change.

Every effort is made to attract the best mechanics in each community to Cessna service facilities. Many Dealers' mechanics have attended Cessna Aircraft Company schools and received specialized instruction in maintenance and care of Cessna airplanes. Cessna service instruction activity in the form of service bulletins and letters is constantly being carried on so that when you have your Cessna inspected and serviced by Cessna Dealers' mechanics the work will be complete and done in accordance with the latest approved methods.

Cessna Dealers maintain stocks of genuine Cessna parts and service facilities consistent with the demand.

Your Cessna Dealer will be glad to give you current price quotations on all parts that you might need and also will advise you on the practicability of parts replacement versus repairs that might be necessary from time to time.

AIRPLANE FILE.

There are miscellaneous data, information and licenses that are a part of the airplane file. The following is a check list for that file. In addition, a periodic check of the latest Civil Air Regulations should be made to insure that all data requirements are met.

A. To be carried in the airplane at all times:

- (1) Aircraft Registration Certifi-

cate (Form ACA 500A).

- (2) Aircraft Airworthiness Certificate (Form ACA 1362).

- (3) Airplane Radio Station License (if transmitter installed).

- (4) Airplane Log Book.

- (5) Engine Log Book.

B. To be maintained but not necessarily carried in the airplane at all times:

- (1) Weight and Balance report or latest copy of the Repair and Alteration Form (ACA 337).

- (2) Equipment List.

- (3) A form containing the following information: Model, Registration Number and Key Numbers. (Duplicate keys are available through your Cessna dealer.)

Most of the requirements listed under items A and B are requirements of the United States Civil Air Regulations. Since the requirements of other nations may differ from this list, owners of exported airplanes should check with their own aviation officials to determine their individual requirements.

LUBRICATION AND SERVICING.

Specific lubrication points, intervals and specifications are shown in figure 5-1. In addition, all pulleys, the trim tab screwjack actuator rod, control surface hinge bearings, bell-crank clevis bolts, flap actuating handle, brake pedal pivots, rudder pedal crossbars, shimmy dampener pivot bushings, door hinges and latches, Bowden controls, and control

FUEL SYSTEM INSTRUMENTS.

Two electrically-operated fuel quantity indicators (figure 1-3) are provided; each being utilized in conjunction with an electrical fuel level transmitter in its respective tank to show the amount of fuel remaining in that tank. The indicators should show the same amount of fuel, relative to each other, when the airplane is level because the tanks are interconnected.

NOTE

After the master switch is pulled on, a warming period is required before the indicator needles will arrive at the actual reading. Also, the needles will require several seconds to readjust themselves to the actual reading after an abrupt change in flight attitude of the airplane.

A red arc extending from the empty to 1/4 full range on each indicator dial warns the pilot that the respective tank is 1/4 full or less. Take-off is not recommended if the pointer is in the red arc. The fuel remaining in the tanks after the indicator pointers reach the red radial line at "E" (3.5 gallons total) is considered unusable in flight.

ELECTRICAL SYSTEM.

Electrical energy is supplied by a 12-volt, direct-current system (figure 1-5) powered by an engine-driven 20-amp generator. A 12-volt storage battery serves as a standby power source, supplying current to the sys-

tem when the generator is inoperative such as when the generator voltage is insufficient to close the reverse-current relay. The battery is located in the fuselage tailcone just aft of the baggage compartment, and is accessible by unsnapping the rear baggage compartment curtain. Refer to the servicing diagram (figure 5-1) for information on servicing the battery.

Control of the charging current and voltage is accomplished by the voltage regulator mounted on the firewall.

NOTE

Only those persons familiar with the operation, adjustment, and repair of the voltage regulator should be permitted to remove the cover.

MASTER SWITCH.

A master switch (figure 1-2) controls the entire airplane electrical system except the magneto-powered ignition system. When the master switch is pulled on, a solenoid switch is energized and the electrical power of the battery is admitted into the electrical system. If the battery is allowed to get sufficiently low, it will not have enough energy to actuate the solenoid when the master switch is pulled on resulting in the generator being unable to charge the battery. In this case, the battery should be recharged prior to flight.

The airplane normally should not be operated without a battery or with the battery disconnected. Damage to the generator and voltage regulator may be the result. In the event

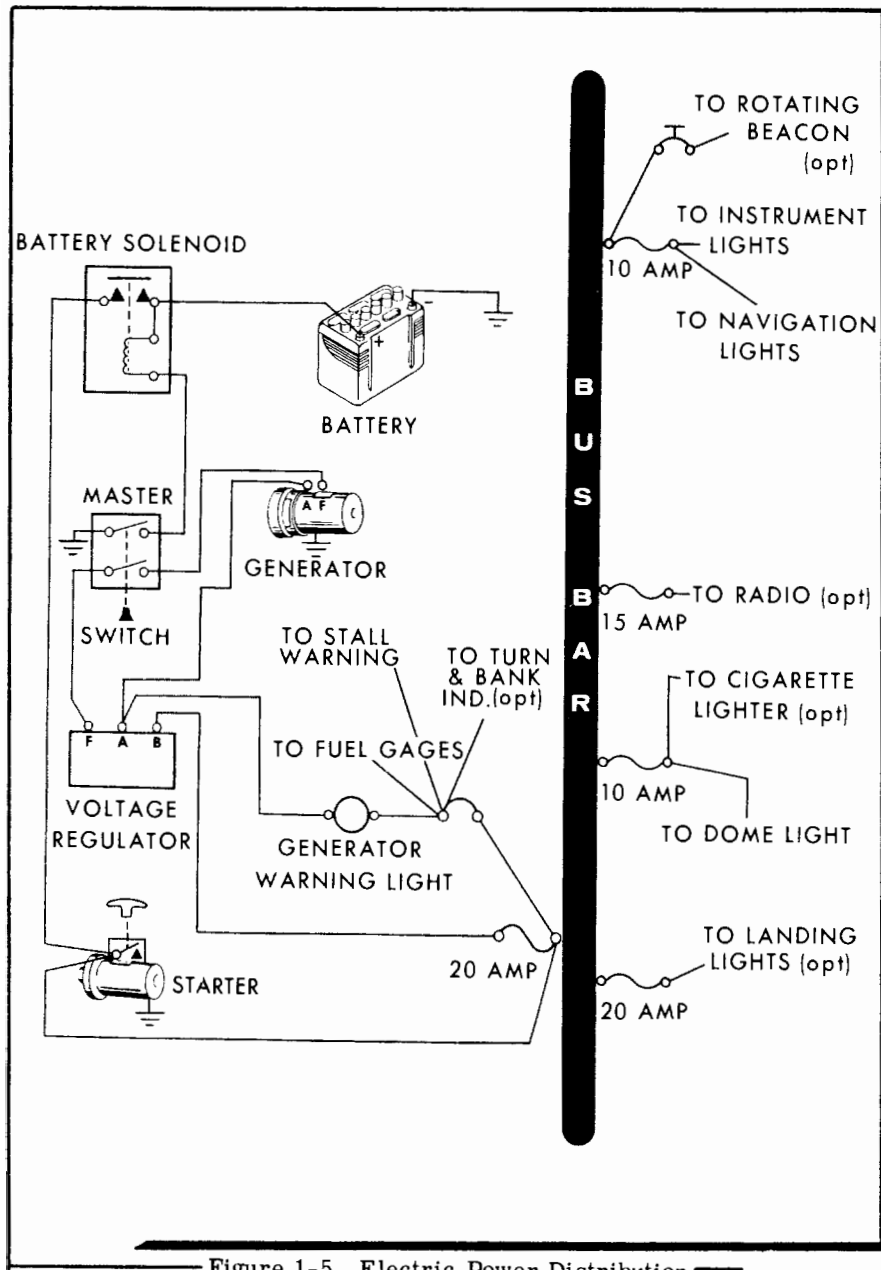

Figure 1-5. Electric Power Distribution

upper fairing plate back until it clears the strut barrel. Rotate the plate to release the spring clips which fasten it to the fairing proper, and remove it. Then rotate the fairing so the wheel fork will pass through.

NOTE

The strut must be disassembled to remove earlier fairings which were made in one piece.

When changing a tire with optional "Speed Fairings," check the clearance between the tire and the mud scraper. Proper clearance is .19 to .31 inch on the nosewheel and .25 to .38 inch on the main wheels. To adjust a scraper, loosen the scraper attaching screws on each side of the fairing, move the scraper as required and retighten the screws. Do not pry between the scraper and the fairing. The clearance check is of particular importance if a recapped tire is installed, since the growth of the tire carcass in service may have increased its diameter.

INSPECTION SERVICE AND INSPECTION PERIODS.

With your airplane you will receive an Owner's Service Policy. This policy has coupons attached to it which entitle you to a no-charge initial inspection and a no-charge 100-hour inspection. If you take delivery from your Dealer, he will perform the initial inspection before delivery of the airplane to you. If you pick up the airplane at the

factory, plan to take your Cessna to your Dealer reasonably soon after you take delivery on it. This will permit him to check it over and to make any minor adjustments that may appear necessary. Also plan an inspection by your Dealer at 100 hours or 90 days whichever comes first. This inspection also is performed by your Dealer for you at no charge. While these important inspections will be performed for you by any Cessna Dealer, in most cases you will prefer to have the Dealer from whom you purchase the airplane accomplish this work.

The Civil Air Regulations require all airplanes to have a periodic (annual) inspection as prescribed by the administrator, by a person designated by the administrator, and in addition, 100-hour periodic inspections made by an "appropriately rated mechanic" if the airplane is flown for hire. The Cessna Aircraft Company recommends the 100-hour periodic inspection for the Model 150 airplanes. The procedure for this 100-hour inspection has been carefully worked out by the factory and is followed by the Cessna Dealer Organization. The complete familiarity of the Cessna Dealer Organization with Cessna equipment and Cessna procedures provides the highest type of service possible at lowest cost.

Time studies of the 100-hour inspection at the factory and in the field have developed a standard flat rate charge for this inspection at any Cessna Dealer. Points which the inspection reveals require modification or repairs will be brought to your attention by the Dealer and

tire clears the ground.

(2) Remove the wheel hub fairing (if installed), cotter pin, and wheel axle nut.

(3) Pull the wheel from the axle.

(4) Remove the grease seals and bearings from each side of the two-piece wheel, then disassemble it to remove the tire. Make sure that the tire is completely deflated before taking the wheel apart. A large O-ring seal is installed between the wheel halves to prevent leakage of air when tubeless tires are used. During disassembly and reassembly, be careful not to damage the seal.

(5) The wheel is reassembled and installed by reversing the above procedure. When installing the wheel on the airplane, the wheel axle nut should be tightened finger tight plus one-half turn.

Nose Gear Wheel and Tire.

(1) Jack the nose or weight down the tail to raise the nosewheel clear of the ground. Chock the main wheels before lifting the nosewheel for wheel removal.

(2) Remove the cotter pin, nut, and axle bolt from the nosewheel axle.

(3) Slide the nosewheel assembly out of the nose gear fork.

(4) Remove the ferrule, bearing grease seals, and bearing from each side of the wheel; remove the axle.

(5) Disassemble the two piece wheel and remove the tire. Be sure that the tire is completely deflated before taking the wheel apart. A large O-ring seal is installed between the wheel halves to prevent

leakage of air when tubeless tires are used. During disassembly and reassembly, be careful not to damage this seal.

(6) The wheel is reassembled and installed by reversing the above procedure. Refer to the servicing diagram (figure 5-2) for the recommended tire inflation procedure and correct tire pressure.

SPEED FAIRING REMOVAL.

If your airplane is equipped with landing gear "Speed Fairings" (Optional Equipment), it is necessary to remove the main wheel fairings, and disconnect the nosewheel fairing prior to removing the main and nosewheels and tires. To remove or disconnect the fairings for wheel removal proceed in accordance with the following instructions.

Main Gear Fairings:

(1) Remove bolt and washers from outboard side of fairing.

(2) Remove six screws and washers from inboard side of fairing.

(3) Lift fairing from main wheel.

(4) Remove main wheel and tire in the usual manner.

Nose Gear Fairing:

(1) Remove cotter pin, nut and washer from either side of fairing at axle location, and pull axle stud out of nosewheel axle.

(2) Remove nut, washers and bolt from top attachment point on fairing.

(3) Slide fairing upward to permit removal of wheel.

(4) Remove the nosewheel and tire in the usual manner, then slip the

of a short or malfunctioning of the airplane electrical system, the master switch may be pushed to the off position and the engine will continue to run on the magneto ignition system.

FUSES.

Fuses (figure 1-3) protect the electrical circuits in your airplane. The circuit and fuse capacity are indicated above each fuse retainer. Fuses are removed by pressing the fuse retainers inward and rotating them counterclockwise until they disengage. The faulty fuse may then be lifted out and replaced. Spare fuses are held in a clip on the inside of the glove compartment door.

The fuel quantity indicators, stall warning system, and turn-and-bank indicator (optional equipment) circuits are protected by an automatically-reset circuit breaker which provides intermittent emergency operation of these devices in case of a faulty circuit. The rotating beacon system (optional equipment) is protected by a separate switch incorporating a circuit breaker.

GENERATOR WARNING LIGHT.

The red generator warning light (figure 1-2) indicates generator output. The light, when on, indicates that the electrical system is receiving current from the battery and the generator is not functioning. Failure of the light to illuminate, when the master switch is pulled on prior to starting the engine, will indicate faulty wiring, a dead battery, or a malfunctioning light. The light should

fade out at approximately 1000 RPM showing that the generator is functioning properly and is supplying current to the system. If the light should illuminate above this RPM, a malfunctioning generator or regulator, or a short in the generator circuit is indicated. It is possible, under extreme electrical loads, to draw current from the battery to supplement the current of the generator; however, the generator warning light will not indicate this drain on the battery as long as the generator is functioning properly. Therefore, the warning light is not to be used as a battery charge indicator.

LANDING GEAR SYSTEM.

MAIN LANDING GEAR.

Your airplane is equipped with Cessna's "Land-O-Matic" landing gear. It consists of a single tapered spring leaf for each main gear. The springs are made from the highest quality chrome vanadium steel, heat treated and shot peened for added fatigue resistance. No maintenance of the springs is necessary other than paint to prevent rusting.

NOSE GEAR.

The nose gear is steerable and incorporates an air and oil shock strut and a shimmy dampener. Nosewheel steering is accomplished through normal operation of the rudder pedals. The wheel is steerable through an arc of approximately 10° each side of neutral, after which it becomes free-swiveling up to a maximum deflection

of 30° right or left of center. The nosewheel is automatically centered while the airplane is in flight, and movement of the rudder pedals will not affect its position. Thus the pilot has the assurance that the nosewheel will be straight at the initial landing touchdown.

Refer to the servicing diagram (figure 5-1) for the nose gear shock strut and shimmy dampener servicing procedure, and servicing intervals.

WHEELS AND TIRES.

Cast aluminum wheels and newly-designed gear tooth-type brake discs simplify and reduce the cost of brake system maintenance.

The airplane is equipped with tubeless tires on the main and nose landing gear wheels. The tires incorporate a new design feature which eliminates the conventional filler valve stem. The tires are inflated through a small blue-colored rubber valve device on the tire sidewall using a special filler needle.

Refer to the servicing diagram (figure 5-1) for the discussion of tire inflation, and to Section V for wheel and tire removal.

SPEED FAIRINGS (OPTIONAL EQUIPMENT).

Landing gear "Speed Fairings" and a propeller spinner are available as optional equipment kits. The fairings are designed as a closely fitted housing for each wheel and

tire, and add to the beauty of your airplane. Because of the small clearance between the tire and fairing, the wheel opening should be kept free of mud, snow, or ice as these elements will have a braking effect on the wheel if allowed to accumulate. If these elements cannot be avoided, make an inspection of the fairings before each flight and remove any accumulations which may be forming.

Refer to paragraph LANDING GEAR CARE for discussion of wheel and tire removal.

BRAKE SYSTEM.

The hydraulic brakes on the main wheels are conventionally operated by applying toe pressure to either the pilot's or copilot's rudder pedals. The rotation of the pedals actuates the brake master cylinders resulting in a braking action on the main landing gear wheels. The brakes may also be set by operating the parking brake knob. Refer to figure 1-6 for parking brake operation.

CABIN HEATING AND VENTILATING SYSTEM.

Cabin heat is provided by a manifold-type heater. The cabin heat knob (figures 1-3 and 1-7) actuates a valve on the firewall which controls the amount of heated fresh air entering the cabin. When the knob is pulled full out, maximum heat is provided. No heat is provided when the knob is in. Intermediate positions of the

up an electrostatic charge on the plastic so that it attracts dust particles from the air. Wiping with a damp chamois will remove this charge as well as the dust and is therefore recommended.

Remove oil or grease from the plastic by rubbing lightly with a cloth wet with kerosene.

NOTE

Do not use gasoline, alcohol, acetone, carbon tetrachloride, fire extinguisher or de-icing fluid, lacquer thinner or glass window cleaning spray as they will soften the plastic and cause crazing.

If after removing dirt and grease no great amount of scratching is visible, apply a good grade of commercial wax in a thin even coat and bring it to a high polish by rubbing lightly with a clean, dry, soft flannel cloth. The wax will fill in minor scratches and help prevent further scratching.

Do not use a canvas cover for protection of the windshield when the airplane is moored outside, unless freezing rain or snow is expected, as it may cause the plastic to craze.

Metal propeller care is limited to inspection, cleaning, and minor repair of small dents, nicks, and scratches. Occasionally wiping the propeller with an oily cloth will clean off grass and bug stains and will assist in corrosion proofing in salt water areas. When small dents and nicks are found, they should be carefully dished and shallowed out using

a fine file, sandpaper, and crocus cloth. More extensive damage must be repaired by a CAA Certified Propeller Repair Station. Your Cessna Dealer should be consulted.

Care of the landing gear is discussed under separate paragraphs in this section.

INTERIOR CARE.

Keeping the inside of your airplane clean is no more difficult than taking care of the rugs and furniture in your home. It is a good idea to occasionally take the dust out of the upholstery with a whisk broom and a vacuum cleaner.

If spots or stains get on the upholstery they should be removed as soon as convenient before they have a chance to soak and dry. Any good grade of commercial cleaning fluid may be used for cleaning the upholstery.

NOTE

Don't use too much fluid as the seat cushions are padded with foam rubber and polyurethane. Some volatile cleaners may attack these materials.

WHEEL AND TIRE REMOVAL.

Main and nose gear wheels and tires are removed and disassembled for repair or replacement in accordance with the following instructions:

Main Gear Wheels and Tires:

- (1) Jack the main gear until the

wheel back with the pilot's safety belt.

STORAGE.

The all-metal construction of your Cessna makes outside storage practical. Inside storage will increase its life just as inside storage does for your car. If an airplane must remain inactive for a time, cleanliness is probably the most important consideration, whether your airplane is stored inside or outside.

Do not neglect the engine when storing the airplane. Turn the propeller over by hand or have it turned over every few days to keep the engine bearings, cylinder walls, and internal parts lubricated. Fuel tanks should be kept full during storage to help prevent moisture condensation and increase fuel tank life.

Airplanes are built to be used and regular use tends to keep them in good condition. An airplane left standing idle for any great length of time is likely to deteriorate more rapidly than if it is flown regularly, and should be carefully checked over before being put back into service.

EXTERIOR CARE.

A minimum of care is required to keep the aluminum exterior surfaces of your airplane bright and polished. Clear water should be used to remove dirt; gasoline, carbon tetrachloride or other non-alkaline grease solvents to remove oil and grease. Household type detergent soap powders are effective cleaners, but should be used cautiously since

some are strongly alkaline. Dulled aluminum surfaces may be cleaned effectively with Bon-Ami. A cleaning solution consisting of about two quarts of alcohol, two quarts of water, and a package of powdered Bon Ami will be found to be particularly effective in cleaning the aluminum.

With only a minimum of care, the lacquered exterior of your Cessna will retain its brilliant gloss and rich color for many years. Do not wax or polish the lacquer for approximately 30 days after it is applied, so that any solvent remaining in the paint may escape. After the initial curing period, regular waxing with a good automotive wax will help preserve the lacquer's luster and will afford a measure of protection from damage.

Spilled fluids containing dyes, such as fuel and hydraulic oil, if accidentally spilled on the surface should be flushed away at once to avoid a permanent stain. Battery electrolyte must be flushed off at once, and the area neutralized with an alkali such as baking soda solution, followed by a thorough rinse with clear water.

The plastic windshield and windows should be kept clean and waxed at all times. To clean the plastic, wash with plenty of soap and water, using the palm of the hand to feel and dislodge any caked dirt or mud. A soft cloth, sponge, or chamois may be used, but only as a means of carrying water to the plastic. Dry with a clean, damp chamois.

NOTE

Rubbing with a dry cloth builds

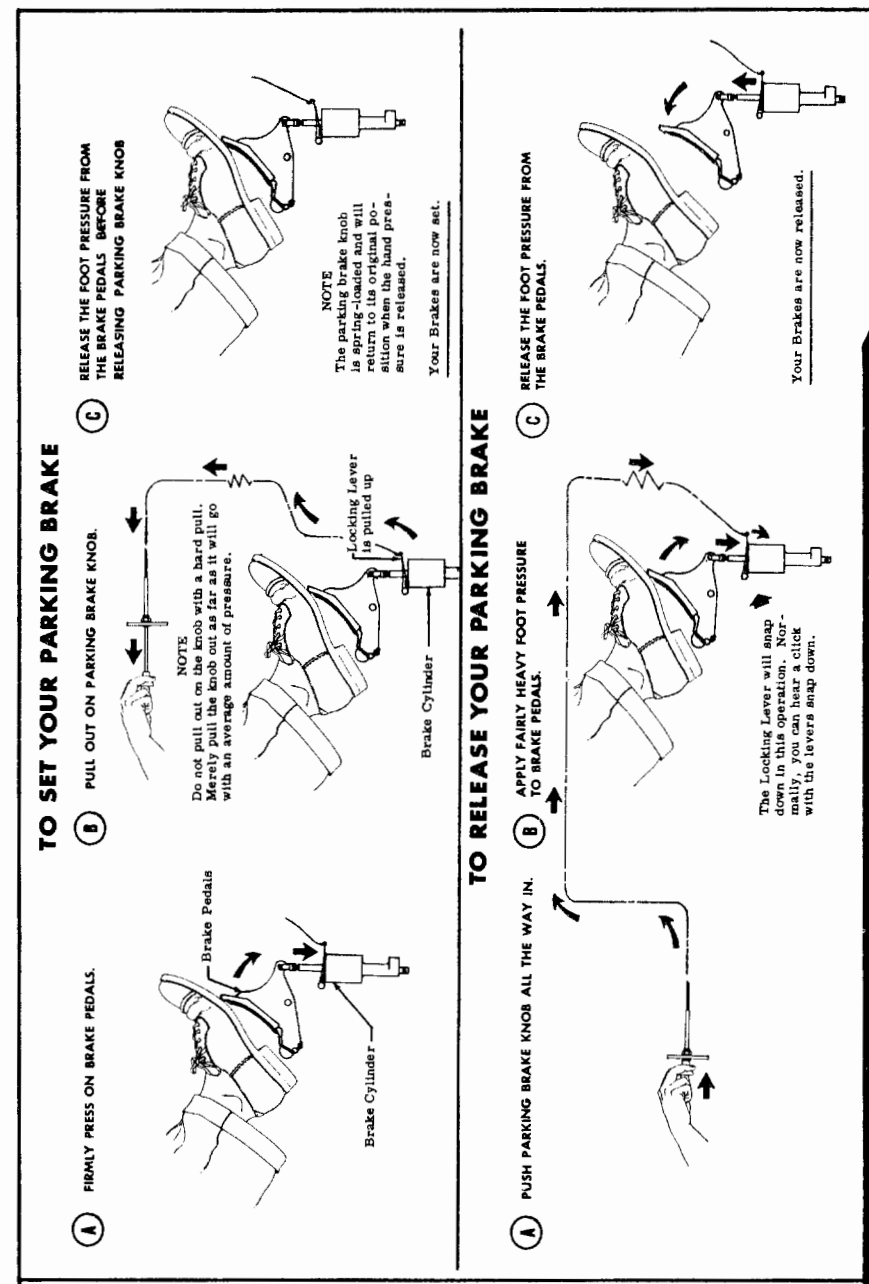

Figure 1-6. Parking Brake Operation

Description

knob may be selected as desired.

Ventilation for the cabin, excluding the ventilation obtained through the cabin heat system, is provided by manually-adjusted cabin ventilators in the upper corners of the windshield. To provide a flow of fresh air, pull the ventilator tube out. The amount of air entering the cabin can be regulated by varying the distance the ventilator tube is extended. To change the direction of airflow, rotate the ventilator tube to the position desired. To stop the flow of air, push the ventilator tube all the way in.

LIGHTING EQUIPMENT.

NAVIGATION LIGHTS.

Conventional wing and tail navigation lights are standard equipment on your airplane. The navigation lights switch (figure 1-3) turns on the lights when pulled out.

NAVIGATION LIGHT DETECTORS.

Optional plastic detectors on the wing tip lights glow when the lights are burning. The glowing tips of the detectors are visible from the pilot's seat.

INSTRUMENT LIGHTS.

A red flood light is mounted on the cabin ceiling to illuminate the instrument panel. The light, in conjunction with the compass light and radio dial lights, is controlled by a rheostat switch. To turn on the lights, rotate the rheostat switch knob (figure 1-2) clockwise until the desired illumination is obtained. To turn

off the lights turn the knob counterclockwise.

DOMELIGHT.

A white dome light in the cabin ceiling is controlled by a slide switch mounted just forward of the dome light.

LANDING LIGHTS (OPTIONAL EQUIPMENT).

The landing lights consist of two lamps mounted side-by-side in the leading edge of the left wing. One lamp is adjusted to give proper illumination of the runway during landing and take-off while the other lamp provides illumination of the ground for taxiing purposes. The landing light switch (figure 1-3), when pulled out to the first stop, turns on the taxi light; when pulled to the second stop, it turns on both the landing light and taxi light. The full in position of the switch is "OFF."

ROTATING BEACON (OPTIONAL EQUIPMENT).

A rotating beacon is installed on the tip of the vertical fin, and serves as an anti-collision light. When the beacon is turned on, its lights rotate continuously through 360°.

NOTE

The rotating beacon should be turned off during flight through clouds to prevent a distracting glare.

The rotating beacon switch (figure 1-2) incorporates a manually-set

SECTION V

Care of the Airplane



If your airplane is to retain that new plane performance, stamina, and dependability, certain inspection and maintenance requirements must be followed. It is always wise to follow a planned schedule of lubrication and maintenance based on the climatic and flying conditions encountered in your locality.

Keep in touch with your Cessna dealer, and take advantage of his knowledge and experience. He knows your airplane and how to maintain it. He will remind you when lubrications and oil changes are necessary and about other seasonal and periodic services.

GROUND HANDLING.

The airplane is most easily and safely maneuvered, during ground handling, by the use of a tow-bar (optional equipment) attached to the nosewheel. Always use a tow-bar when one is available. When moving the airplane by hand and no tow-bar is available, push down at the front edge of the stabilizer adjacent to the fuselage to raise the nosewheel off the ground. With the nosewheel clear of the ground the airplane can be turned in any direction by pivoting it about the main gear. When moving the airplane forward or backward, push at the wing strut root fitting or at the main gear strut.

MOORING YOUR AIRPLANE.

Proper tie-down is the best precaution against damage to your parked airplane by gusty or strong winds. To tie down your airplane securely,

proceed as follows:

- (1) Tie sufficiently strong (700 pounds tensile strength) ropes or chains to the tie-down ring located at the upper end of each strut, and secure the opposite ends to tie-down rings suitably anchored in the ground.
- (2) Tie a rope to an exposed portion of the engine mount, and secure the opposite end to a tie-down ring in the ground.
- (3) Securely tie the middle of a length of rope to the tie-down ring at the tail. Pull each end of the rope away at a 45° angle and secure to tie-down rings in the ground positioned on each side of the tail.
- (4) Install an external gust lock between the flap and aileron of each wing.
- (5) Install an external gust lock over the fin and rudder.
- (6) Install the controls lock (optional equipment) on the pilot's control column, or if a controls lock is not available, tie the pilot's control

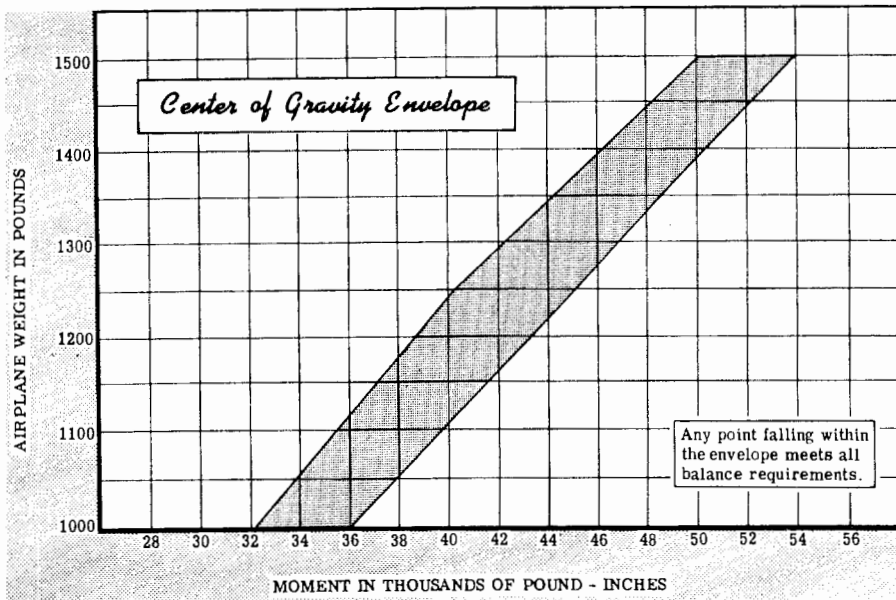

Figure 4-1. Center of Gravity Envelope

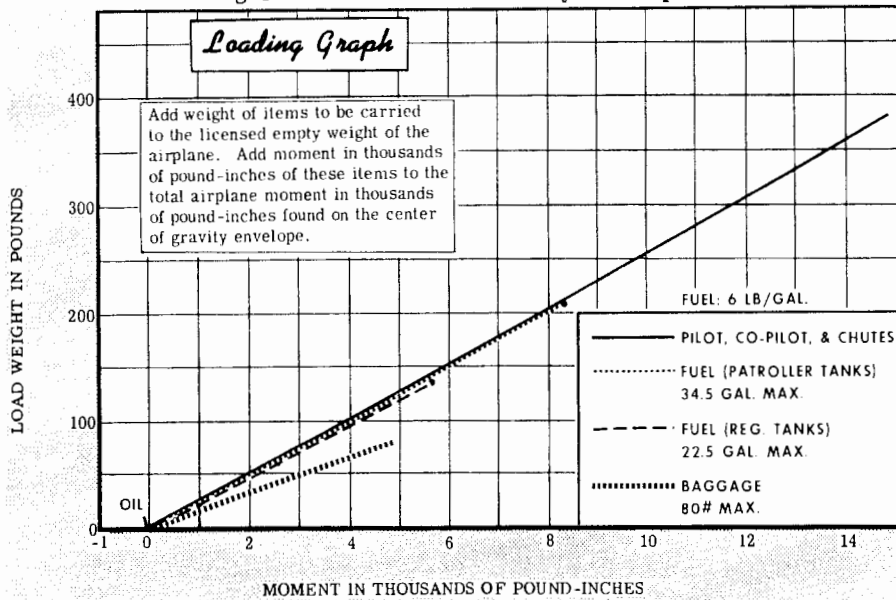

Figure 4-2. Loading Graph

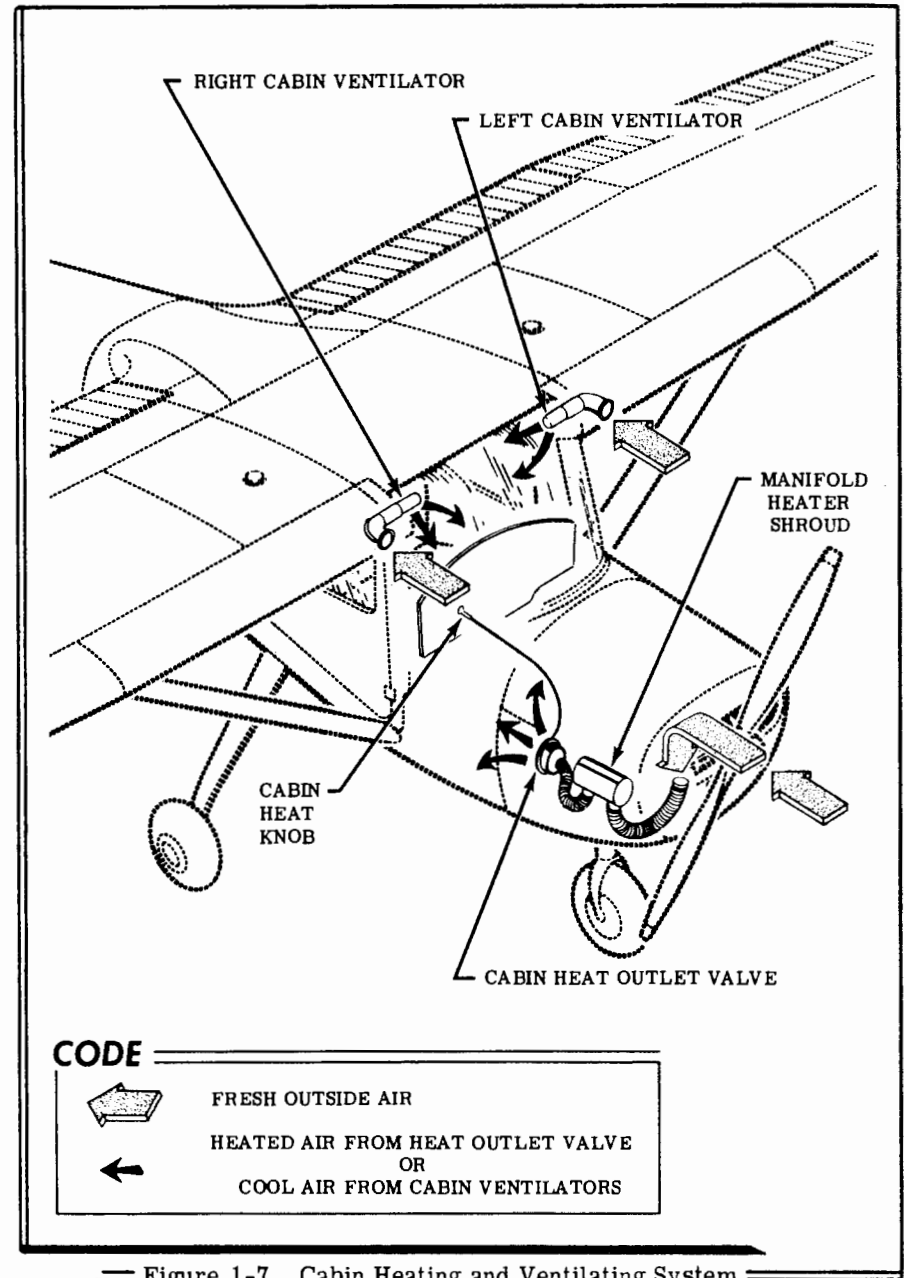

Figure 1-7. Cabin Heating and Ventilating System

circuit breaker. Pushing the switch button in turns on the rotating beacon. To turn off the beacon, pull the switch button out. A short in the circuit will also open the circuit breaker and force the button out.

MISCELLANEOUS EQUIPMENT.

SEATS.

Two large cushioned seats with a common adjustable seat back are provided. The seat back is adjustable to four positions at the bottom and three positions at the top, and pivots forward and down for access to the baggage compartment.

The lower adjustment of the seat back permits seating at the most comfortable distance from the rudder pedals. To adjust the bottom of the seat back, grasp the spring-loaded pivot pin on the left side of the seat and pull the pin from the adjustment hole. Position the seat as desired making sure that both the fixed pivot pin on the right and the spring-loaded pin on the left are properly aligned, then release the left pivot pin to secure the seat. Check that the pins are fully inserted in the proper adjustment holes.

The upper adjustment determines the reclining angle of the seat back. This adjustment is made by gripping the handle behind the center of the seat back, and positioning the seat back to the desired angle.

CHILD'S SEAT (OPTIONAL EQUIPMENT).

A small seat may be installed just aft of the front seats in place of the

baggage compartment and utility shelf. This seat provides seating space for children or space for baggage up to a maximum of 80 pounds. The back of the seat is hinged at the top and may be lifted up (after removing the seat pad and retaining screws on the seat back) to permit access to the battery whenever battery servicing or replacement is necessary.

CABIN DOORS.

Cabin doors permit entry from either side of the airplane. Each door has a flush-mounted door handle on the outside and a conventional type handle on the inside. To open the door from the outside, pull out on the forward edge of the flush-mounted handle. To open the door from the inside, rotate the inside door handle forward.

The right cabin door can be locked from the inside only. To lock the door, press down on the lock button located at the lower rear corner of the door window. Lift the lock button to unlock the door.

The left door can be locked from the outside only with a key-operated lock. The same key operates both the door lock and the ignition.

CABIN WINDOWS.

The window in each cabin door may be opened to provide cabin ventilation during engine warm-up and taxiing. The two rear windows are of the fixed type. The cabin door windows are hinged along the top of the windows and open out and up. To open these

TACHOMETER.

Normal Operating Range:

- At sea level 2000-2500 (inner green arc)
- At 5000 feet 2000-2650 (middle green arc)
- At 10,000 feet 2000-2750 (outer green arc)
- Maximum Allowable. 2750 (red line)

WEIGHT AND BALANCE.

All aircraft are designed for certain limit loads and balance conditions. These specifications for your 150 are charted on page 4-4.

A weight and balance data sheet and equipment list for your particular airplane when it left the factory is furnished with the airplane. Changes in original equipment affecting empty weight c.g. are required by the FAA to be recorded in the Repair and Alteration Form ACA-337. Using the weight and moment of your empty airplane, and following the example shown, the moment for take-off weight may be readily calculated. This moment, when plotted on the center of gravity envelope, will quickly show whether or not the c.g. is within limits. Refer to the loading graph for moment values of items to be carried.

EXAMPLE PROBLEM

	WT (LBS.)	MOMENT (1000 LB. -INS.)
EMPTY WEIGHT (Licensed)	985.0	+31.3
OIL	11.0	- 0.1
PILOT AND PASSENGER	340.0	+13.3
FUEL (Total Usable) 22.5 GAL . .	135.0	+ 5.7
BAGGAGE (To Make Gross Weight) .	29.0	+ 1.9
TOTAL	1500.0	+52.1

Locate this point (1500 at 52.1) on the center of gravity envelope graph, and, since the point falls within the envelope, the above loading meets all balance requirements.

NOTE

The above problem is only one of many different loading configurations. To best utilize the available payload for your airplane, the loading graph on page 4-4 should be consulted to determine proper load distribution.

Spins with flaps down are prohibited due to the fact that recovery cannot be made without exceeding flap design speeds. Acrobatics that may impose high inverted loads should not be attempted. The important thing to bear in mind in flight maneuvers is that the Cessna 150 is clean in aerodynamic design and will build up speed quickly with the nose down. Proper speed control is an essential requirement for execution of any maneuver, and care should always be exercised to avoid excessive speed which in turn can impose excessive loads. In the execution of all maneuvers, avoid abrupt use of controls.

AIRSPED LIMITATIONS.

The following are the certificated true indicated airspeed limits for the Cessna 150:

- Maximum (Glide or dive, smooth air) 157 MPH (red line)
- Caution Range 120-157 MPH (yellow arc)
- Normal Range 54-120 MPH (green arc)
- Flap Operating Range 50-85 MPH (white arc)
- Maneuvering Speed* 106 MPH

*The maximum speed at which you can use abrupt control travel without exceeding the design load factor.

ENGINE OPERATION LIMITATIONS.

- Power and Speed 100 BHP at 2750 RPM

ENGINE INSTRUMENT MARKINGS.

OIL TEMPERATURE GAGE.

- Normal Operating Range Green Arc
- Maximum Allowable Red Line

OIL PRESSURE GAGE.

- Minimum Idling 10 PSI (red line)
- Normal Operating Range 30-60 PSI (green arc)
- Maximum 100 PSI (red line)

FUEL QUANTITY INDICATORS.

- Empty (1.75 gallons unusable each tank) E (red line)
- *Not recommended for take-off E to 1/4 (red arc)
- *This fuel is available for all normal operations.

windows, pull up and push out on the window latch. With the window latch completely extended, the window will remain open. To close the windows, pull the window latch in and down.

FIRE EXTINGUISHER (OPTIONAL EQUIPMENT).

A portable fire extinguisher may be installed behind the right rear door post just under the utility shelf. In this location, it does not interfere with the loading of baggage and yet is quickly accessible. In case of emergency, rotate the back of the seat forward in the usual manner, remove the extinguisher from its storage bracket, and use it in accordance with the instructions on the

extinguisher.

BAGGAGE COMPARTMENT.

The baggage compartment just aft of the seats has a capacity of 80 pounds. To gain access to the baggage compartment, grip the handle behind the center of the seat back and pull it full forward to disconnect the top of the seat back from the cabin sidewall. The back then may be pivoted full forward and down.

UTILITY SHELF.

A utility shelf just above the baggage compartment is convenient for storing hats, brief cases, and other small articles.

SECTION IV

Operating Limitations

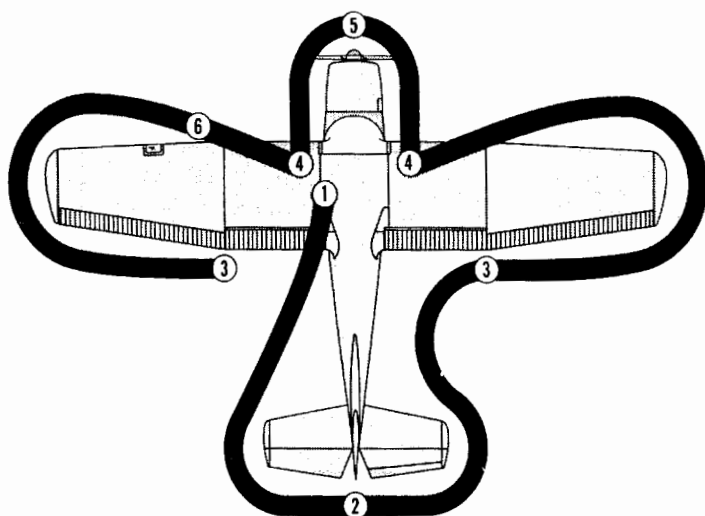

- ① (a) Remove control wheel lock if installed.
- (b) Turn on master switch and check fuel quantity indicators. (Several seconds of warm up must be allowed for correct indication.)

NOTE

Take-off with both fuel quantity indicators in the red arc (below 1/4) is not recommended.

- (c) Make sure master and ignition switches are "OFF," check fuel shutoff valve safetied in "ON" position.
- (d) Adjust seat back for comfort and distance to rudder pedals.
- ② (a) Remove rudder lock, if installed.
- (b) Inspect tail surface hinges and hinge bolts.
- (c) Check elevator trim tab for security.
- (d) Disconnect tie-down rope or chain.
- ③ (a) Remove aileron lock, if installed.
- (b) Check aileron and flap hinges.
- ④ (a) Check main wheel tire for cuts, bruises, and proper inflation.
- (b) Inspect airspeed static source hole on side of fuselage for stoppage, (left side only).
- (c) Remove fuel tank cap and check fuel level for agreement with gage reading. Secure cap.
- (d) Disconnect tie-down rope or chain from tie-down ring on wing strut.
- ⑤ (a) Check windshield for cleanliness.
- (b) Check oil level. Do not operate with less than 4 quarts. Fill for extended flight.
- (c) Inspect cowl access door for security.
- (d) On first flight of day, drain a two-ounce quantity of fuel from the fuel strainer to check for presence of water and sediment.
- (e) Check propeller and spinner for nicks and security.
- (f) Check nosewheel strut for proper inflation.
- (g) Check nosewheel tire for cuts, bruises, and proper inflation.
- (h) Disconnect tie-down rope.
- ⑥ (a) Remove pitot tube cover if installed.
- (b) Inspect pitot tube opening for stoppage.
- (c) Check fuel tank vent opening for stoppage.

Figure 2-1. Exterior Inspection Diagram

OPERATIONS AUTHORIZED.

Your Cessna 150, with standard equipment as certified under FAA Type Certificate No. 3A19, is approved for day and night operation under VFR.

Additional optional equipment is available to increase its utility and to make it authorized under IFR day and night.

Your airplane must be operated in accordance with all FAA approved markings, placards and check lists in the airplane. If there is any information in this section which contradicts the FAA approved markings, placards and check lists, it is to be disregarded.

MANEUVERS — UTILITY CATEGORY.

This airplane is not designed for purely aerobatic flight. However, in the acquisition of various certificates such as commercial pilot, instrument pilot and flight instructor, certain maneuvers are required by the FAA. All of these maneuvers are permitted in the Cessna 150. In connection with the foregoing, the following gross weights and flight load factors apply, with recommend entry speeds for maneuvers as shown.

Maximum Design Weight.	1500 lbs.
Flight Maneuvering Load Factor, *Flaps Up.	+4.4 -1.76
Flight Maneuvering Load Factor, *Flaps Down	+3.5

*The design load factors are 150% of the above and in all cases the structure meets or exceeds design loads.

No acrobatic maneuvers are approved except those listed below:

MANEUVER	RECOMMENDED ENTRY SPEED
Chandelles.	106 MPH (92 Knots)
Lazy Eights	106 MPH (92 Knots)
Steep Turns	106 MPH (92 Knots)
Spins	Use Slow Deceleration
Stalls	Use Slow Deceleration

SECTION II

Operating Check List

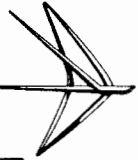

This section lists, in Pilot's Check List form, the steps necessary to operate your Cessna efficiently and safely. The section is intentionally brief and is designed as a "quick reference" source of operating procedures. More detailed information on operating characteristics and techniques may be found in Section III; operational limitations are in Section IV.

All airspeeds mentioned in Sections II and III are indicated airspeeds. Corresponding true indicated airspeeds may be obtained from the airspeed correction table in Section VI.

BEFORE ENTERING THE AIRPLANE.

- (1) Perform an exterior inspection of the airplane (see figure 2-1).

BEFORE STARTING THE ENGINE.

- (1) Safety belt -- Fasten and check.
- (2) Flight controls -- Operate and check visually.
- (3) Brakes -- Test for condition.
- (4) Parking brake -- Set.

STARTING THE ENGINE.

- (1) Carburetor air -- Cold.
- (2) Mixture -- Rich.
- (3) Primer -- Two strokes during the initial start in normal air temperatures. Usually a hot engine will need no priming.
- (4) Propeller area -- Check clear.
- (5) Master switch -- "ON."
- (6) Ignition switch -- "BOTH."
- (7) Throttle -- Open 1/4-inch.
- (8) Starter handle -- Pull.

WARM-UP AND GROUND TEST.

- (1) Throttle -- 800 RPM.

NOTE

Do not allow the engine to operate at more than 800 RPM for the first 60 seconds after starting. After starting, if the oil pressure gage does not begin to show pressure within 30 seconds in

the summer time and about twice that long in very cold weather, stop the engine and investigate. Lack of oil pressure may cause serious engine damage.

- (2) Carburetor heat -- Cold (unless icing conditions prevail).
- (3) After one to two minutes running at 800 RPM, continue warm-up at not more than 1600 RPM while taxiing to the active runway. Do not overheat the engine by running it at high power while on the ground. When the engine accelerates smoothly and the oil pressure remains steady, you are ready for take-off.

NOTE

To avoid propeller tip abrasion, do not run up the engine on loose cinders or gravel.

BEFORE TAKE-OFF.

- (1) Altimeter -- Set.
- (2) Elevator trim -- "TAKE-OFF."
- (3) Oil pressure -- 30 to 60 lbs./sq. in. (Minimum idling oil pressure -- 10 lbs./sq. in.)
- (4) Ignition switch -- Check magnetos at 1600 RPM. The maximum allowable RPM drop is 125 RPM on either magneto.
- (5) Engine operation -- Check. A full throttle RPM check is unnecessary and not recommended. However, when the condition of the engine is in doubt, check that the engine runs smoothly up to a full throttle static RPM of 2320 to 2470 with carburetor heat off. The engine should idle at 500 RPM.

TAKE-OFF.

NORMAL TAKE-OFF.

- (1) Flaps -- Retracted (0°).
- (2) Carburetor air -- Cold.
- (3) Throttle -- Full OPEN.
- (4) Rudder pedals -- Keep heels on floor to avoid dragging brakes.
- (5) Control wheel -- Apply slight back pressure to raise the nose-wheel when take-off speed is reached.

NOTE

Do not raise the nose of the airplane excessively high as this will lengthen the take-off run.

priming). After priming, push the primer knob all the way in and turn to a locked position.

During cold weather operations, no indication will be apparent on the oil temperature gage prior to take-off if outside air temperatures are very cold. After a suitable warm-up period (2 to 5 minutes at 1000 RPM), accelerate the engine several times to a higher engine RPM. If the engine accelerates smoothly and the oil pressure remains normal and steady, the airplane is ready for take-off.

When operating in sub-zero temperatures, avoid using partial carburetor heat. Partial heat could increase the carburetor air temperature to the 32°F to 80°F range where icing is critical under certain atmospheric conditions.

For operation at temperatures consistently below freezing, a winterization kit is available at your distributor or dealer. The kit consists of a molded restrictor plate which is fastened over the cowl nose cap, thereby restricting the flow of cold air through the engine section.







=Power Off= STALLING SPEEDS MPH=TIAS				
Gross Weight 1500 lbs.	ANGLE OF BANK			
	 0°	 20°	 40°	 60°
CONDITION				
Flaps Up 	54	56	62	77
Flaps 10° 	53	55	61	75
Flaps 40° 	50	52	58	71

Figure 3-2. Stall Chart

landing speed and the subsequent need for braking in the landing roll. The nosewheel is lowered gently to the runway after the speed is diminished. This procedure is especially important in rough field landings.

Heavy braking in the landing roll is not recommended because of the probability of sliding the main wheels with the resulting loss of braking effectiveness and damage to the tires.

COLD WEATHER OPERATION.

Prior to starting the engine on cold mornings, it is advisable to pull the propeller through several times by hand to "break loose" or "limber" the oil, conserving battery energy. In extremely cold (-20°F) weather,

prime the engine as follows:

- (1) Propeller area -- Check clear.
- (2) Master switch -- Pull "ON."
- (3) With ignition switch "OFF" and the throttle closed, prime the engine four to ten strokes as the engine is being turned over.
- (4) Ignition switch -- Turn to "BOTH."
- (5) Throttle -- Open 1/4" (to idle position).
- (6) Starter handle -- Pull to start engine.

NOTE

In extremely cold weather, a few strokes of the primer as the engine fires will enable the engine to keep running. (Avoid over-

- (6) Climb at 71 MPH.

OBSTACLE CLEARANCE TAKE-OFF.

- (1) Flaps -- Retracted (0°).
- (2) Brakes -- Hold.
- (3) Throttle -- Full OPEN.
- (4) Brakes -- Release.
- (5) Take-off slightly tail low.
- (6) Accelerate to best angle of climb speed (55 MPH).

MINIMUM GROUND RUN -- SOFT OR ROUGH FIELD TAKE-OFF (NO OBSTACLES AHEAD).

- (1) Flaps -- 10°.
- (2) Take-off in tail low attitude.
- (3) Level off momentarily to accelerate to a safe airspeed.
- (4) Flaps -- Retract slowly as soon as a reasonable altitude is obtained. (See TAKE-OFF paragraph on page 3-3 for further discussion of use of flaps.)

TAKE-OFF IN STRONG CROSSWIND.

- (1) Flaps -- Retracted (0°).
- (2) Throttle -- Full OPEN.
- (3) Control wheel -- Use sufficient aileron into the wind to maintain wings level and hold nosewheel on ground 5 to 10 MPH above normal take-off speed; then take-off abruptly to prevent airplane from settling back to runway while drifting.

CLIMB.

- (1) If no obstacle is ahead, climb out with flaps up at 75-80 MPH with full throttle. If maximum rate of climb is desired use full throttle and 71 MPH at sea level (see figure 6-2). Reduce climb speed about 1/2 MPH for every 1000 feet of altitude above sea level.
- (2) To climb over an obstacle after take-off use the best angle of climb speed of 55 MPH with full throttle and flaps up.
- (3) Mixture -- Rich (unless engine is rough due to rich mixture).

CRUISING.

- (1) Recommended cruising RPM -- 2000 to 2750 RPM (see page 4-3).
- (2) Elevator trim -- Trim for cruise.
- (3) Oil pressure -- 30 to 60 lbs./sq. in.
- (4) Oil temperature -- Within green arc.
- (5) Mixture -- Lean to maximum RPM or lean as required to obtain smooth engine operation when using carburetor heat in cruise.

BEFORE LANDING.

- (1) Mixture -- Rich.
- (2) Carburetor air -- Apply full heat before closing throttle.
- (3) Glide at 65 to 75 MPH with flaps up.
- (4) Flaps -- As desired below 85 MPH.
- (5) Maintain 60 to 70 MPH with flaps extended.
- (6) Elevator trim -- Trim for glide.

LANDING.**NORMAL LANDING.**

- (1) Landing technique is conventional for all flap settings.

SHORT FIELD LANDING.

- (1) Make a power-off approach at 61 MPH, with 40° flaps (fourth notch).
- (2) Land on main wheels first.
- (3) Control wheel -- Lower nosewheel to ground immediately after touchdown.
- (4) Brakes -- Apply heavy braking as required.

NOTE

Excessive braking will skid tires, resulting in lengthened ground run and tire damage.

LANDING IN STRONG CROSSWIND.

- (1) Flaps -- Use minimum setting required for field length.
- (2) Use wing low, crab, or combination method of drift correction.
- (3) Land in a nearly level attitude.
- (4) Hold straight course with steerable nosewheel and occasional braking if necessary.

AFTER LANDING.

- (1) Flaps -- Retracted (0°) after completion of landing roll.
- (2) Normal glide and taxiing should cool engine sufficiently. However, if an excessive amount of taxiing is necessary, allow engine to cool by idling at 600 to 800 RPM two to three minutes.
- (3) Mixture -- Lean to stop engine. Do not open throttle as engine stops.
- (4) Ignition switch -- "OFF" (after engine stops).
- (5) All other switches -- Turn to "OFF."
- (6) Parking brakes -- Set brakes, if required.

CLIMB.

For detailed climb data, refer to the climb performance chart in Section VI. Normal climbs are conducted at 75 to 80 MPH with flaps up and full throttle for best engine cooling. Mixture should be full rich unless the engine is rough due to rich mixture, then lean for smooth operation. The best rate-of-climb speeds range from 71 MPH at sea level to 66 MPH at 10,000 feet. If obstruction dictates the use of a steep climb angle, the best angle-of-climb speed should be used with flaps up and full throttle. These speeds vary from 55 MPH at sea level to 59 MPH at 10,000 feet.

FLIGHT CHARACTERISTICS.

The flight and operational characteristics of the Cessna Model 150 are normal in all respects. There are no "unconventional" characteristics or operations that need to be mastered. All controls respond in the normal way within the entire range of operation of the airplane.

CRUISE.

For cruise data, refer to the cruise performance chart in Section VI. Range and endurance figures are given for lean mixture from 2500 feet to 12,500 feet. All figures are based on zero wind, 22.5 gallons of fuel for cruise, the Sensenich M69CK-52 propeller and standard atmospheric conditions. The mixture should be leaned until the RPM decreases slightly, then enriched

to maximum RPM. Allowances for fuel reserve, headwinds, take-offs and climb, and variations in mixture leaning technique should be made and are in addition to the figures shown on the chart. Other indeterminate variables such as carburetor metering characteristics, engine and propeller conditions, and turbulence of the atmosphere may result in variations of 10% or more in maximum range.

STALLS.

The stalling speeds shown (see figure 3-2) are for forward c.g., full gross weight conditions. Other loadings result in slower stalling speeds. The stall warning horn produces a steady signal 5 to 10 MPH before the actual stall is reached and remains on until the airplane flight attitude is changed. Fast landings will not produce a signal.

The stall characteristics are conventional for the flaps up and flaps down condition. Slight elevator buffeting may occur just before the stall with flaps down.

LANDING TECHNIQUES.

Normal landings are made power off with any flap setting. Approach glides are normally made at 65 to 75 MPH with flaps up or 60 to 70 MPH with flaps down, depending upon the turbulence of the air. The elevator trim tab may be adjusted in the glide to relieve elevator control forces.

Landings are usually made on the main landing wheels to reduce the

undue wear and strain on tires, brakes, and landing gear. Normal steering is accomplished by applying pressure to the rudder pedal in the direction the airplane is to be turned. For smaller radius turns, at slow speed, the brakes may be used on the inside wheel. At slow taxi speed, this airplane may be pivoted around the outboard strut fitting without sliding the tires. When taxiing in a crosswind, hold down your speed and brake gently. Use all controls (see figure 3-1) to hold your directional control and balance.

NOTE

Strong quartering tailwinds require caution. Avoid quick bursts of the throttle and sharp braking when the airplane is in this attitude. Use the steerable nosewheel and rudder to maintain direction. Caution should be used when taxiing over rough fields to avoid excessive loads on the nosewheel. Rough use of brakes and power also add to nosewheel load. A good rule of thumb: "Use minimum speed, power, and brakes."

Taxiing over loose gravel or cinders should be done at low engine speed to avoid abrasion and stone damage to the propeller tips. Full throttle run-ups over loose gravel are especially harmful to propeller tips. When take-offs must be made over a gravel surface, it is very important that the throttle be advanced slowly. This allows the airplane to start rolling before high RPM is developed,

and the gravel will be blown back of the propeller rather than pulled into it. When unavoidable small dents appear in the propeller blades, they should be immediately corrected as described in Section V under EXTERIOR CARE.

TAKE-OFF TECHNIQUES.

Normal and obstacle clearance take-offs are performed with flaps retracted. Minimum ground run and soft or rough field take-offs are performed with 10° flaps. With the flaps extended 10°, ground run is reduced approximately 10% but the total distance over a 50 foot obstacle remains the same.

NOTE

Do not use 30° and 40° flaps for take-off.

General rules for flap operation during take-off are as follows:

Under marginal conditions, release the flaps before you start losing both climb and airspeed.

Release flaps with airspeed well above flaps up stalling speed. (See figure 3-2).

Slowly release the flaps as soon as practical after take-off, preferably 50 feet or more over terrain.

Consult the take-off chart (see figure 6-2) for take-off distances under various altitude conditions.

SECTION III

Operating Details



The following paragraphs cover in somewhat greater detail the items entered as a Check List in Section II. Only those items on the Check List that required further explanation will be found in this section; those which are self-explanatory have been omitted.

CLEARING THE PROPELLER.

"Clearing" the propeller should become a habit with every pilot. Making sure no one is near the propeller before the engine is started should be a positive action. Shouting "clear" in loud tones is best.

ENGINE OPERATING PROCEDURES.

You have a new Continental engine made to the highest standards available. This engine has been carefully operated in its run-in and flight tests so that the engine, as you receive it, is in the best possible condition. Proper engine operation will pay you rich dividends in increased engine life. The following points are mentioned so that you may receive the maximum of trouble-free operation and low maintenance cost.

TAKE-OFF.

Most engine harm results from improper operation before the engine is properly warmed and temperatures stabilize. For this reason, on your take-off, use maximum power only as necessary for safe operation of the airplane, reducing power as

soon as practical.

CRUISING.

The maximum recommended engine speeds for cruising are 2500 RPM at sea level, 2650 RPM at 5000 feet and 2750 RPM at 10,000 feet. These RPM's will produce approximately 70% power at the given altitudes. Greater range can be obtained at lower RPM settings as shown in the Cruise Performance Chart (see figure 6-3). At any cruising altitude, adjust the mixture control knob for best power by pulling the knob out until the RPM decreases slightly then push the control knob forward to maximum RPM. Readjust for each change in power, altitude, or carburetor heat.

LET-DOWN.

The cruising glide should begin far enough away from the destination so that a gradual descent can be made with power on and with mixture full rich. On approaching the landing field, the engine should be throttled down gradually and the glide, with closed throttle, should not be longer than necessary.

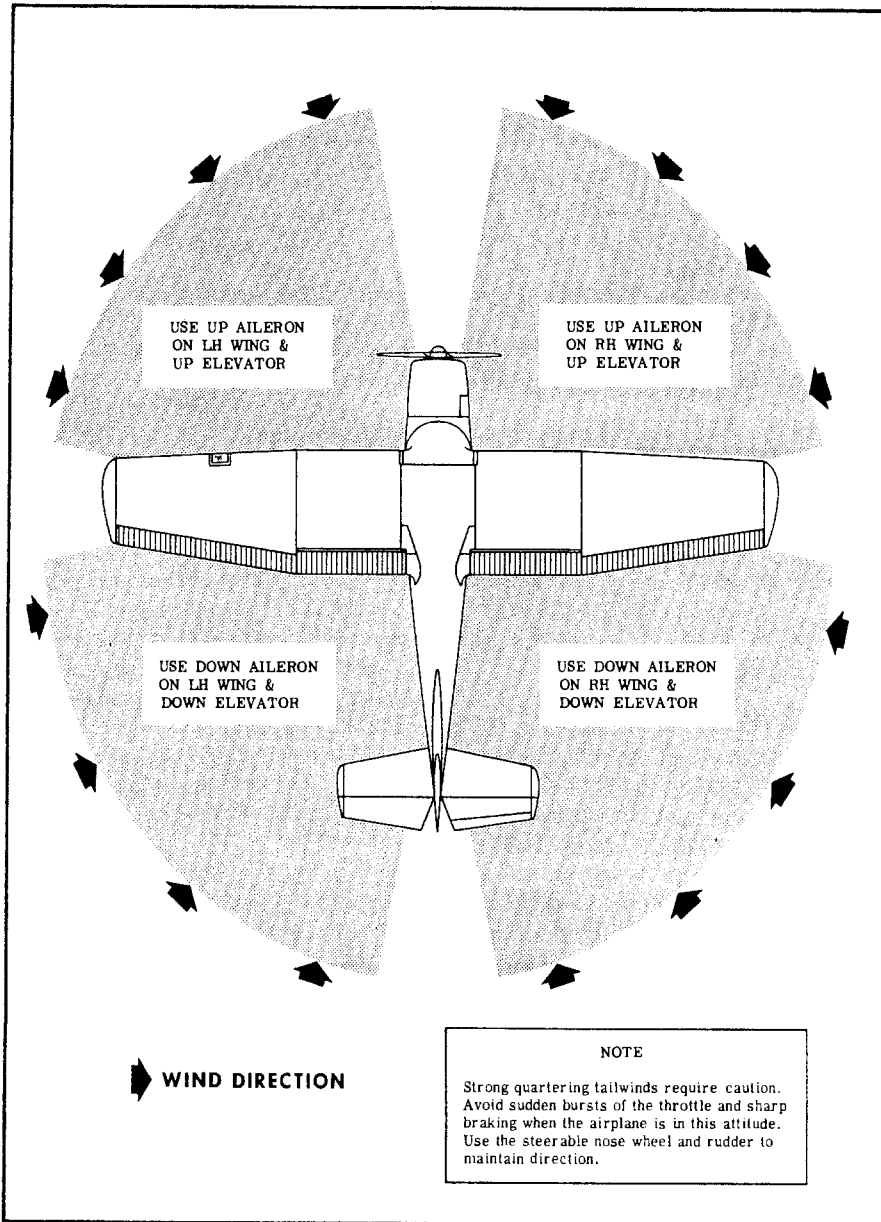

Figure 3-1. Taxiing Tips for Strong Crosswinds

IDLING ENGINE.

Your engine is set to idle well below 600 RPM, but at engine speeds below 600 RPM, satisfactory piston lubrication cannot be maintained. Therefore, it is recommended that the engine not be allowed to operate below 600 RPM for prolonged intervals.

USE OF CARBURETOR HEAT.

Air pulled into the heater muff and subsequently into the engine does not pass through the carburetor air filter. For this reason, when taxiing on dirty, dusty, or sandy fields, carburetor heat should not be used until the engine is cleared prior to take-off. After a full stop landing under these conditions, carburetor heat should be returned to the full cold position (knob pushed full in) in order that the air filter becomes fully effective again.

Carburetor ice can form during ground operation with the engine idling. Therefore, just after the magneto check prior to take-off, pull out the carburetor air heat knob to check the operation of carburetor heat, and also to eliminate any ice forming in the carburetor. After this short check, be sure to move the carburetor air heat knob to the full cold position. This gives maximum power for the take-off. Watch the engine for any indications of ice (roughness or loss of RPM) during climb and apply full carburetor heat if the engine begins to ice.

The correct way to use carburetor heat is to first use full heat to remove any ice that is forming. By

trial and error, determine the minimum amount of heat required to prevent the ice from forming; each time removing any ice that is formed by using full heat. On each subsequent trial increase the amount of heat applied until no ice forms. On approach glide just before reducing power, apply full carburetor heat and leave in this position. Refer to paragraph COLD WEATHER OPERATION, for discussion of the use of carburetor heat when operating in sub-zero temperatures.

If ice is present, the application of carburetor heat will cause only slight RPM drop. When full carburetor heat is applied, and no ice is present, the engine will lose up to 150 RPM in cruising flight or 250 RPM at full throttle. In addition to the RPM loss, the engine will run rough due to too rich a mixture. Therefore, it may be necessary to lean the mixture whenever full carburetor heat is used. Excessively lean fuel-air mixture will cause overheating and possible detonation. Do not lean the mixture unless an increase in engine RPM results.

TAXIING.

Release the parking brakes before taxiing, and use the minimum amount of power necessary to start the airplane moving. During taxi, and especially when taxiing downwind, the RPM should be held down to prevent excessive taxi speeds. Taxiing should be done at a speed slow enough to make the use of brakes almost entirely unnecessary. Using the brakes as sparingly as possible will prevent